



Page 4-2

DIRECT-ON-LINE STARTERS WITH AND WITHOUT THERMAL RELAY

- Motor ratings up to 95A 440V in IEC AC3 duty
- General use up to 65A / motor rating up to 52A 600V per UL/CSA
- Versions with Start-Stop/Reset buttons or Reset button.



Page 4-5

REVERSING CONTACTOR ASSEMBLIES

- For three-phase motor control 9-25A 440V / 4-12.5kW 400V, in IEC AC3 duty and up to 15HP 600V per UL/CSA
- Versions with built-in or external mechanical interlock
- Complete with rigid connections
- PCB version 9A 440V / 4kW 400V in IEC AC3 duty; 5HP 300V per UL/CSA.



Page 4-5

CHANGEOVER CONTACTOR ASSEMBLIES

- For 20A loads at $\leq 40^{\circ}\text{C}$ in IEC AC1 duty
- For 20A general use per UL/CSA
- With built-in mechanical interlock.



Page 4-6

STAR-DELTA STARTERS OPEN FRAME

- Suitable for three-phase motor control, 16A-690A 440V / 7.5kW-375kW 400V ratings in IEC AC3 duty.



Page 4-7

STAR-DELTA STARTERS IN NON-METALLIC ENCLOSURE

- Suitable for three-phase motor control, 16-60A 440V / 7.5kW-30kW 400V ratings in IEC AC3 duty.



Page 4-8

EMPTY NON-METALLIC ENCLOSURES

- Versions without pushbuttons, with Reset button only or Start-Stop/Reset buttons
- For starters, with pushbuttons and metal plate
- Suitable to contain BG mini-contactor or BF09A to BF110 contactors, up to 110A 440V rating in IEC AC3 duty; up to 52A at 600V for UL/CSA.

ELECTROMECHANICAL STARTERS



- Direct-on-line starters in non-metallic enclosure complete with or without thermal relay
- Versions with RESET or START/STOP pushbuttons
- Non-metallic enclosures for customer-assembled starters
- Reversing and changeover contactor assemblies
- Star-delta starters, open frame and in non-metallic enclosure versions.

	SEC. - PAGE
Direct-on-line starters - Full voltage across the line - Non reversing	
Enclosed with thermal relay	4 - 2
Enclosed without thermal relay	4 - 3
Combinations	4 - 10
Reversing contactor assemblies	
With BG series mini-contactors	4 - 5
With BF series contactors	4 - 5
Changeover contactor assemblies	
With BG series mini-contactors	4 - 5
Star-delta starters	
Open frame	4 - 6
Enclosed	4 - 7
Non-metallic enclosure for starters	4 - 7
Empty non-metallic enclosures	
Enclosures	4 - 8
Accessories and spare parts	4 - 8
Combinations	4 - 9
Dimensions	4 - 16
Wiring diagrams	4 - 20



Electromechanical starters

Direct-on-line starters - Full voltage across the line. Non reversing three phase

Enclosed with thermal overload relay

4



MO P...12 MO R...12



M1 P...12 M1 R...12



M2 P...12 M2 R...12



M25 P038 12



M25 R038 12



M3 P...12



M3 R...12

new

new

Order code	Relay adj range	IEC technical characteristics (≤440V)		Qty per pkg	Wt
		I _e [A]	P _e [kW]		

Starters with Start and Stop/Reset pushbuttons ①.

MO P009 1201	0.6-1	1	0.18-0.25	1	0.760
MO P009 1201V5	0.9-1.5	1.5	0.37	1	0.760
MO P009 1202V3	1.4-2.3	2.3	0.55-0.75	1	0.760
MO P009 12033	2-3.3	3.3	1.1	1	0.760
MO P009 1205	3-5	5	1.5-2.2	1	0.760
MO P009 12075	4.5-7.5	7.5	2.2-3	1	0.760
MO P009 12010	6-10	10	3-4	1	0.760
MO P012 12015	9-15	12	5.5	1	0.760
M1 P009 120A4	0.63-1	1	0.25	1	1.040
M1 P009 120A5	1-1.6	1.6	0.37-0.55	1	1.040
M1 P009 120A6	1.6-2.5	2.5	0.75	1	1.040
M1 P009 120A7	2.5-4	4	1.1-1.5	1	1.040
M1 P009 120A8	4-6.5	6.5	2.2-3	1	1.040
M1 P009 120A9	6.3-10	10	3-4	1	1.040
M1 P009 120B0	9-14	13	5.5	1	1.040
M1 P018 120B1	13-18	18	7.5	1	1.040
M2 P025 120B2	17-23	23	11	1	1.220
M2 P025 120B3	20-25	25	11	1	1.220
M2 P032 120B4	24-32	32	15	1	1.300
M25 P038 120B5	32-38	38	18.5	1	2.880
M3 P050 120B6	35-50	50	18.5-22	1	3.760
M3 P065 120B7	45-65	65	30	1	3.760
M3 P080 120B8	60-82	80	37-45	1	3.760
M3 P095 120B9	70-95	95	45	1	3.760

Starters with Reset pushbuttons ②.

MO R009 1201	0.6-1	1	0.18-0.25	1	0.720
MO R009 1201V5	0.9-1.5	1.5	0.37	1	0.720
MO R009 1202V3	1.4-2.3	2.3	0.55-0.75	1	0.720
MO R009 12033	2-3.3	3.3	1.1	1	0.720
MO R009 1205	3-5	5	1.5-2.2	1	0.720
MO R009 12075	4.5-7.5	7.5	2.2-3	1	0.720
MO R009 12010	6-10	10	3-4	1	0.720
MO R012 12015	9-15	12	5.5	1	0.720
M1 R009 120A4	0.63-1	1	0.25	1	0.995
M1 R009 120A5	1-1.6	1.6	0.37-0.55	1	0.995
M1 R009 120A6	1.6-2.5	2.5	0.75	1	0.995
M1 R009 120A7	2.5-4	4	1.1-1.5	1	0.995
M1 R009 120A8	4-6.5	6.5	2.2-3	1	0.995
M1 R009 120A9	6.3-10	10	3-4	1	0.995
M1 R009 120B0	9-14	13	5.5	1	0.995
M1 R018 120B1	13-18	18	7.5	1	0.995
M2 R025 120B2	17-23	23	11	1	1.165
M2 R025 120B3	20-25	25	11	1	1.165
M2 R032 120B4	24-32	32	15	1	1.260
M25 R038 120B5	32-38	38	18.5	1	2.600
M3 R050 120B6	35-50	50	18.5-22	1	3.410
M3 R065 120B7	46-65	65	30	1	3.410
M3 R080 120B8	60-82	80	37-45	1	3.410
M3 R095 120B9	70-95	95	45	1	3.410

① Complete order code with coil voltage digit (if 50/60Hz) or with voltage digit followed by 60 (if 60Hz).
Standard voltages are as follows:
- AC 50/60Hz 024 / 048 / 110 / 230 / 400V
- AC 60Hz 024 60 / 048 60 / 120 60 / 220 60 / 230 60 / 460 60 / 575 60 (V).
Example: MO R009 12 024 1 for direct-on-line starter in MO type enclosure with Reset button, 9A/AC3 contactor with 24VAC 50/60Hz coil and 0.6-1A thermal overload relay.
MO P009 12 024 60 1 for direct-on-line starter in MO type enclosure with Start and Stop/Reset buttons, 9A /AC3 contactor with 24VAC 60Hz coil and 0.6-1A thermal overload relay.

② Protection fuses are to be mounted externally by the user.

Components	Starter enclosure	Contactor	Thermal relay	Auxiliary contact block
MO PA		BG09 10A	RF9 1	—
MO PA		BG09 10A	RF9 1V5	—
MO PA		BG09 10A	RF9 2V3	—
MO PA		BG09 10A	RF9 33	—
MO PA		BG09 10A	RF9 5	—
MO PA		BG09 10A	RF9 75	—
MO PA		BG09 10A	RF9 10	—
MO PA		BG12 10A	RF9 15	—
M1 PA		BF09 10A	RF38 0100	—
M1 PA		BF09 10A	RF38 0160	—
M1 PA		BF09 10A	RF38 0250	—
M1 PA		BF09 10A	RF38 0400	—
M1 PA		BF09 10A	RF38 0650	—
M1 PA		BF09 10A	RF38 1000	—
M1 PA		BF09 10A	RF38 1400	—
M1 PA		BF18 10A	RF38 1800	—
M2 PA		BF25 10A	RF38 2300	—
M2 PA		BF25 10A	RF38 2500	—
M2 PA		BF32 00A	RF38 3200	G418 10
M25 PA		BF38 00A	RF38 3800	G418 10
M3 PA		BF50 00	RF95 3 50	G418 10
M3 PA		BF65 00	RF95 3 65	G418 10
M3 PA		BF80 00	RF95 3 82	G418 10
M3 PA		BF95 00	RF95 3 95	G418 10

MO RA		BG09 10A	RF9 1	—
MO RA		BG09 10A	RF9 1V5	—
MO RA		BG09 10A	RF9 2V3	—
MO RA		BG09 10A	RF9 33	—
MO RA		BG09 10A	RF9 5	—
MO RA		BG09 10A	RF9 75	—
MO RA		BG09 10A	RF9 10	—
MO RA		BG12 10A	RF9 15	—
M1 RA		BF09 10A	RF38 0100	—
M1 RA		BF09 10A	RF38 0160	—
M1 RA		BF09 10A	RF38 0250	—
M1 RA		BF09 10A	RF38 0400	—
M1 RA		BF09 10A	RF38 0650	—
M1 RA		BF09 10A	RF38 1000	—
M1 RA		BF09 10A	RF38 1400	—
M1 RA		BF18 10A	RF38 1800	—
M2 RA		BF25 10A	RF38 2300	—
M2 RA		BF25 10A	RF38 2500	—
M2 RA		BF32 00A	RF38 3200	G418 10
M25 RA		BF38 00A	RF38 3800	G418 10
M3 RA		BF50 00	RF95 3 50	G418 10
M3 RA		BF65 00	RF95 3 65	G418 10
M3 RA		BF80 00	RF95 3 82	G418 10
M3 RA		BF95 00	RF95 3 95	G418 10

Operational characteristics
Certifications and compliance
Refer to page 4-3 for details.

Special M3... versions
Refer to page 4-3 for details.

UL/CSA HP ratings
See page 4-4

Electromechanical starters

Direct-on-line starters - Full voltage across the line.

Non reversing three phase

Enclosed without thermal overload relay



new

new

Order code	Maximum operating current (≤440V)	Qty per pkg	Wt
	[A]	n°	[kg]
Starters with Start and Stop/Reset pushbuttons ②.			
M0 P009 10	10	1	0.667
M0 P012 10	12	1	0.667

M1 P009 10	13	1	0.910
M1 P018 10	18	1	0.910
M2 P025 10	25	1	1.060
M2 P032 10	32	1	1.162

M25 P038 10	38	1	2.360
M3 P050 10	50	1	3.110
M3 P065 10	65	1	3.110
M3 P080 10	80	1	3.110
M3 P095 10	95	1	3.110

Starters with Reset pushbutton ②.			
M0 R009 10	10	1	0.627
M0 R012 10	12	1	0.627
M1 R009 10	13	1	0.867
M1 R018 10	18	1	0.867

M2 R025 10	25	1	1.020
M2 R032 10	32	1	1.110
M25 R038 10	38	1	2.320
M3 R050 10	50	1	3.070
M3 R065 10	65	1	3.070
M3 R080 10	80	1	3.070
M3 R095 10	95	1	3.070

① Complete order code with coil voltage digit if 50/60Hz or with voltage digit followed by 60 if 60Hz.
Standard voltages are as follows:
- AC 50/60Hz 024 / 048 / 110 / 230 / 400V
- AC 60Hz 024 60 / 048 60 / 120 60 / 220 60 / 230 60 / 460 60 / 575 60 (V).
Example: M0 R009 10 024 1 for direct-on-line starter in M0 type enclosure with Reset button, 9A /AC3 contactor with 24VAC 50/60Hz coil.
M0 P009 10 024 60 1 for direct-on-line starter in M0 type enclosure with Start and Stop/Reset buttons, 9A /AC3 contactor with 24VAC 60Hz coil.

② Protection fuses are to be mounted externally by the user.

Starter enclosure standard supplied	Contactor standard supplied	Thermal relay to purchase separately	Auxiliary contact standard supplied
M0 PA	BG09 10A	RF9	—
M0 PA	BG12 10A	RF9	—
M1 PA	BF09 10A	RF38	—
M1 PA	BF18 10A	RF38	—
M2 PA	BF25 10A	RF38	—
M2 PA	BF32 00A	RF38	G418 10
M25 PA	BF38 00A	RF38	G418 10
M3 PA	BF50 00	RF95 3	G418 10
M3 PA	BF65 00	RF95 3	G418 10
M3 PA	BF80 00	RF95 3	G418 10
M3 PA	BF95 00	RF95 3	G418 10
M0 RA	BG09 10A	RF9	—
M0 RA	BG12 10A	RF9	—
M1 RA	BF09 10A	RF38	—
M1 RA	BF18 10A	RF38	—
M2 RA	BF25 10A	RF38	—
M2 RA	BF32 00A	RF38	G418 10
M25 RA	BF38 00A	RF38	G418 10
M3 RA	BF50 00	RF95 3	G418 10
M3 RA	BF65 00	RF95 3	G418 10
M3 RA	BF80 00	RF95 3	G418 10
M3 RA	BF95 00	RF95 3	G418 10

③ For thermal overload relay selection, refer to pages 3-2 or 3-3.
④ For thermal overload relay selection, refer to pages 3-4.
⑤ For thermal overload relay selection, refer to pages 3-4 or 3-5.

Operational characteristics

- Cable entry:
 - M0/M1/M2... - 2 knockouts PG13.5/M20 on enclosure top and bottom
 - M25... - 2 knockouts PG16/M25-PG29/M32 on enclosure top and bottom
 - M3... - Smooth surfaces; can be drilled by customer
- Ambient conditions:
 - Operating temperature: -25...+60°C
 - Storage temperature: -40...+70°C
- Degree of protection: IP65 for all; type 4/4X industrial control environment for M1 / M2 / M25... and M3... UL versions.

Special M3... versions

In addition to standard-indicated versions, cULus certified starters are available up to 52A motor control or 65A general use rating max. Add suffix **UL** to the order code, e.g. M3 P050 10 024**UL**.

UL/CSA HP ratings

See page 4-4

Certifications and compliance

Certifications obtained: EAC for all; UL Listed for USA and Canada (cULus – File E93602) and CSA certified for Canada and USA (cCSAus – File 94157) as Magnetic Motor Controllers, enclosed type, for all M0-M1-M2P/R... starters and M3P/R50-65...UL types as indicated in "Special M3" above. Compliant with standards: IEC/EN 60947-1, IEC/EN 60947-4-1, UL508, CSA C22.2 n° 14.

Electromechanical starters

Direct-on-line starters – Full voltage across the line. Non reversing

CONFIGURATIONS FOR USA AND CANADA.

Order code for magnetic motor starters in non-metallic enclosure with 2 push buttons	T/O RELAY ADJ RANGE [A]	MAX UL/CSA HP RATINGS INDICATED ON STARTER (based on t/o relay adj range)					
		Single phase			Three phase		
		120V	240V	200V	240V	480V	600V
MOP009001	0.6 - 1	-	-	-	-	½	½
MOP00901V5	0.9 - 1.5	-	-	-	-	¾	¾
MOP00902V3	1.4 - 2.3	-	-	-	½	1	1
MOP009033	2 - 3.3	-	¼	¾	1½	2	2
MOP00905	3 - 5	-	½	1	1	3	3
MOP009075	4.5 - 7.5	-	¾	1½	2	5	5
MOP009010	6 - 10	½	1½	2	3	5	5
MOP012015	9 - 15	½	1½	3	3	7½	10
M1P0090A4	0.63 - 1	-	-	-	-	-	½
M1P0090A5	1 - 1.6	-	-	-	-	½	¾
M1P0090A6	1.6 - 2.5	-	-	½	½	1	1½
M1P0090A7	2.5 - 4	-	-	¾	¾	2	3
M1P0090A8	4 - 6.5	¼	½	1	1½	3	5
M1P0090A9	6.3 - 10	½	1½	2	3	5	7½
M1P0090B0	9 - 14	¾	2	3	3	5	7½
M1P0120B0	9 - 14	1	2	5	5	7½	10
M1P0180B1	13 - 18	1	3	5	5	10	15
M2P0250B2	17 - 23	1½	3	5	7½	15	15
M2P0250B3	20 - 25	2	3	7½	7½	15	15
M2P0260B2	17 - 23	1½	3	5	7½	15	20
M2P0260B3	20 - 25	2	5	7½	7½	15	20
M2P0260B4	24 - 32	2	5	7½	7½	15	20
M2P0320B4	24 - 32	3	7½	10	10	20	25
M25P0380B5	32 - 38	3	7½	10	15	30	30
M3P0500B6UL	35 - 50	3	10	10	15	30	40
M3P0650B7UL	46 - 65	-	-	15	15	40	50
M3P0800B8	60 - 82	-	-	25	30	60	75
M3P0950B9	70 - 95	-	-	30	30	60	75

new



NOTE: The HP / FLA values vary from one motor to another; if possible, always verify the HP and FLA (or rated current) on the motor nameplate. Enclosure UL Type 1, 12, 4 and 4X industrial control environment for M1, M2, M25 and M3...UL versions; designation of control units can be:
N – without push buttons
R – with reset button only
P – per table, with start-stop push buttons
S – with start selector and stop push button. Consult Customer Service for any other combination required (e.g. with other type of contactors, contactor assemblies or definite-purpose version, different overload version or range, additional pilot lights, extra electrical or electronic elements); see contact details on inside front cover. Refer to 1 below for specified standard configurations.

- 1 Complete the order code by indicating:
 - 10 if required without thermal overload relay
 - 12 if required with three-phase overload relay
 - 13 if required with single-phase overload relay
 - 15 if required with automatic reset of overload relay for M0 types
 - 17 if required with disconnect switch for M2 and M3 types
 - 42 if required with reversing contactor combination for M2 and M3 types.
- 2 Complete the order code by indicating coil voltage required:
 - 02460 for 24V 60Hz
 - 04860 for 48V 60Hz / 42V 50Hz
 - 12060 for 120V 60Hz / 110V 50Hz
 - 22060 for 220V 60Hz / 200V 50/60Hz
 - 23060 for 230V 60Hz / 220V 50Hz
 - 46060 for 460V 60Hz / 400V 50Hz
 - 57560 for 575V 60Hz.
- 3 Maximum HP ratings per UL and CSA can be different when definite-purpose contactors are considered. Consult with Customer Service for further information; see contact details on inside front cover.
- 4 Short circuit protective device – This enclosed starter is suitable for use on a circuit capable of delivering not more than 5,000 rms symmetrical amperes, 600V max, when protected with Class RK5 type, Fuse size 200A.
- 5 Maximum UL ratings is 52A for motor control and 65A for general use. Short circuit protective device – This enclosed starter is suitable for use on a circuit capable of delivering not more than 10,000 rms symmetrical amperes, 600V max, when protected with Class RK5 type, Fuse size 225A.
- 6 No CSA or UL certification. Indicated values correspond to UL/CSA magnetic contactor ratings and for indication and reference purposes only.
- 7 UL/CSA data for M25 types not available at the time of catalogue printing so for indication and reference purposes only.

- Certifications obtained:**
- CSA certified for Canada and USA (cCSAus - File 94157) as Magnetic Motor Controllers at max 600VAC, max 15HP per single phase, max 60HP three phase, max 125A with general purpose enclosure.
 - UL Listed for USA and Canada (cULus - File E93602) as Magnetic Motor Controllers – Enclosed.

Markings:
Line (voltage and frequency value)
Amps (overload adjustment range)
Max HP (horsepower value)
Control (coil and frequency value)
Caution: Bonding between conduits must be provided.

Electromechanical starters

Reversing and changeover contactor assemblies

Reversing contactor assemblies



11 BGR...



BFA...



11 BGT...



11 BGT...

Changeover contactor assemblies



11 BGC09 ...

Order code	IEC Ie (AC3) ≤440V ≤55°C	Max. IEC power AC3 400V at ≤55°C	Built-in auxiliary contacts	Qty per pkg	Wt
	[A]	[kW]	NO NC	n°	[kg]

AC COIL.
Terminals: clamp screw.
External interlock with power and auxiliary wiring.

11 BGR09 01 A	9	4	0 1	1	0.394
11 BGR12 01 A	12	5.7	0 1	1	0.394
BFA009 42	9	4.2	0 1	1	0.760
BFA012 42	12	5.7	0 1	1	0.760
BFA018 42	18	7.5	0 1	1	0.760
BFA025 42	25	12.5	0 1	1	0.760

Built-in interlock with power wiring only.
11 BGT09 10 A 9 4 1 0 1 0.380
11 BGT12 10 A 12 5.7 1 0 1 0.380

Rear terminals: PCB solder pins.
Built-in interlock only.
11 BGT09 01 A 9 4 0 1 1 0.400

DC COIL.
Terminals: clamp screw.
External interlock with power and auxiliary wiring.

11 BGR09 01 D	9	4	0 1	1	0.460
11 BGR12 01 D	12	5.7	0 1	1	0.460

Built-in interlock with power wiring only.
11 BGT09 10 D 9 4 1 0 1 0.445
11 BGT12 10 D 12 5.7 1 0 1 0.445

Rear terminals: PCB solder pins.
Built-in interlock only.
11 BGT09 01 D 9 4 0 1 1 0.460

Order code	IEC Operating current (AC1)			UL/CSA General Use	Qty per pkg	Wt
	≤40°C	≤55°C	≤60°C	[A]	n°	[kg]
	[A]	[A]	[A]	[A]	n°	[kg]

AC COIL.
Terminals: clamp screw.
Built-in interlock only.
11 BGC09 T4 A 20 18 15 20 1 0.365

DC COIL.
Terminals: clamp screw.
Built-in interlock only.
11 BGC09 T4 D 20 18 15 20 1 0.450

1 Complete order code with coil voltage digit or with voltage digit followed by 60 if 60Hz.
Standard voltages are as follows:
- AC 50/60Hz 024 / 048 / 110 / 230 / 400V
- AC 60Hz 024 60 / 048 60 / 120 60 / 220 60 / 230 60 / 460 60 / 575 60 (V).
Example: 11 BGR09 01 A024 for reversing contactor assembly with 2 mini-contactors BG09 having 1 NC auxiliary contact each and 24VAC 50/60Hz coil.
11 BGR09 01 A024 60 for reversing contactor assembly with 2 mini-contactors BG09 having 1 NC auxiliary contact each and 24VAC 60Hz coil.

2 Complete order code with coil voltage digit.
Standard voltages are:
- DC 012 / 024 / 048 / 060 / 110 / 125 / 220V.
Example: 11 BGC09 T4 D012 is a changeover contactor assembly with 2 mini-contactors BG09 having 4 main poles each and 12VDC coil.

3 One auxiliary contact for each contactor.
4 Maximum voltage is limited at 300V for UL. For certified type up to 600V, consult Customer Service; see contact details on front inside cover.

General characteristics

REVERSING CONTACTOR ASSEMBLIES
Supplied complete, ready for quick mounting.
The various versions are composed as follows:
BGR... Screw termination, external mechanical interlock BGX50 00, power and auxiliary wiring.
BGT... Screw termination, built-in mechanical interlock and power wiring only.
BGT... Rear PCB solder pin termination, built-in mechanical interlock only.
No thermal overload relay can be directly mounted to BG... reversing contactor assemblies.
BFA... Screw termination, mechanical interlock BFX50 02 and power wiring.
The thermal overload relay RF38... can be directly mounted to BFA... reversing contactor assemblies; for selection, refer to section 3.

CHANGEOVER CONTACTOR ASSEMBLIES
Supplied complete, ready for quick mounting as follows:
BGC09 T4 Four-pole contactors with built-in mechanical interlock. No power or auxiliary wiring included.

Operational characteristics

Type	Maximum IEC operational power at ≤55°C (AC3)					
	230V	400V	415V	440V	500V	690V
	[kW]	[kW]	[kW]	[kW]	[kW]	[kW]
BGR09	2.2	4	4.3	4.5	5	5
BGT09	2.2	4	4.3	4.5	5	5
BGT09	2.2	4	4.3	4.5	5	-
BGR12	3.2	5.7	6.2	5.5	5	5
BGT12	3.2	5.7	6.2	5.5	5	5
BFA009	2.2	4.2	4.5	4.8	5.5	7.2
BFA012	3.2	5.7	6.2	6.2	7.5	10
BFA018	4	7.5	9	9	10	10
BFA025	7	12.5	13.4	13.4	15	11

BGC09 T4	at ≤40°C (AC1)					
	8	14	14	15	16	22

	Maximum UL/CSA horsepower rating					
	Single phase			Three phase		
	120V	240V	208V	240V	480V	600V
	[HP]	[HP]	[HP]	[HP]	[HP]	[HP]
BGR09	½	1½	2	3	5	5
BGT09	½	1½	2	3	5	5
BGT09	½	1½	2	3	5	-
BGR12	½	1½	3	3	7½	10
BGT12	½	1½	3	3	7½	10
BFA009	¾	2	3	3	5	7½
BFA012	1	2	5	5	7½	10
BFA018	1	3	5	5	10	15
BFA025	2	3	7½	7½	15	15

NOTE: BGR09, BGT09, BGR12, BGT12... types are UL Listed for USA and Canada as "Magnetic Motor Controller - Reversing Contactors". All these are rated 20A general (purpose) use and suitable for use on a circuit capable of delivering more than 8kA symmetrical. Amps at 600V max when protected by fuses class K5 rated no more than 30A.
BGT09 type is UL Recognized for USA and Canada as "Magnetic Motor Controller - Component - reversing contactors". Max HP rating up to 300VAC only; rated 20A general (purpose) use.
BGC... types are UL Listed for USA and Canada as "Magnetic Motor Controller - Changeover contactor".
No coil change or replacement is possible for any BG... types.

Add-on blocks

Refer to section 2, pages 2-16 and 2-18.
Special add-on auxiliary contacts 11 BGX11 11 or 11 BGX11 12 must be used on the left-side contactor of the BGT reversing assemblies.
For the right-side contactor, normal 11 BGX10... types of auxiliary contacts can be used instead.
Refer to page 2-16 for details.

Certifications and compliance

Certifications obtained: UL Listed for USA and Canada (File E93602) for BGR09, BGT09, BGR12, BGT12, BFA... and BGC... (see NOTE above).
UL Recognized, for USA and Canada (cULus - File E93602 Component), for BGT09; products having this type of marking are intended for use as components of complete workshop-assembled equipment.
Compliant with standards IEC/EN 60947-1, IEC/EN 60947-4-1, UL508, CSA C22.2 n° 14.

Electromechanical starters

Star-delta starters

Open frame

4



BFA...

Order code	Three-phase motor control. Max IEC operating current ($\leq 440V$)	Qty per pkg	Wt
	[A]	n°	[kg]
Complete star-delta starters, open frame, for starting time up to 12 seconds and a maximum of 30 operations/hour.			
BFA009 70	16	1	1.700
BFA012 70	22	1	1.700
BFA018 70	28	1	1.700
BFA025 70	35	1	1.800
BFA026 70	43	1	1.800
BFA032 70	50	1	1.900
BFA038 70	60	1	1.900
21 DYF50 E	85	1	5.200
21 DYF65 E	110	1	5.200
21 DYF80 E	140	1	6.265
21 DYF95 E	145	1	6.265
21 NYF115	220	1	19.000
21 NYF145	260	1	19.000
21 NYF180	310	1	19.000
21 NYF250	480	1	22.650
21 NYF310	530	1	22.650
21 NYF400	690	1	25.000

Operational characteristics

IEC standard motor powers

230V [kW]	400V [kW]	440V [kW]	500V [kW]
4	7.5	7.5	7.5
5.5	11	11	11
7.5	15	11	11
11	18.5	18.5	22
11	22	22	25
15	25	25	25
15	30	30	30
25	45	45	59
30	59	63	75
40	75	80	100
40	75	80	100
63	110	129	147
80	132	162	185
92	160	185	210
145	250	280	315
160	295	335	368
220	375	425	450

Thermal relay adjustment range

Choose the thermal relay adjustment range considering a value equal to 58% of rated motor current (I_e).

Example: $I_e=100A$; 58% $I_e=58A$.

The suitable relay range is 46-65A.

During the setup, the relay is to be regulated at 58A.

For DYF... type

Digit defining thermal relay range	Relay adj range A	IEC aM fuses ① A	DYF starters			
			50	65	80	95
42	28-42	80				
50	35-50	100				
65	46-65	125				
82	60-82	160				
95	70-95	200				

For NYF... type

Digit defining thermal relay range	Relay adj range A	IEC aM fuses ① A	NYF starters							
			115	145	180	250	310	400		
100	60-100	200								
125	75-125	250								
150	90-150	315								
200	120-200	400								
250	150-250	500								
300	180-300	630								
420	250-420	800								

- Complete order code with the coil voltage digit or the coil voltage digit followed by 60 if 60Hz. Standard voltage are as follows:
- AC 50/60Hz 024 / 048 / 110 / 230 / 400V
- AC 60Hz 024 60 / 048 60 / 120 60 / 220 60 / 230 60 (V).

Example: BFA009 70 024 60 for BFA009 star-delta starter with 24VAC 50/60Hz power supply.

- BFA009 70 024 60 for BFA009 star-delta starter with 24VAC 60Hz power supply.
- The thermal overload relay is not included and must be purchased separately. Refer to the example given under Thermal relay adjustment range, for a correct choice and then to page 3-4 for the order code.
- The thermal overload relay is included. Replace with digit of thermal relay; see tables above, under Thermal relay adjustment range.
- To be mounted by the customer.
- Fuses for type 1 co-ordination. For type 2 co-ordination, consult Customer Service; see contact details on inside front cover.
- TM ST with auxiliary supply 24...240VAC. TM ST A440 with auxiliary supply 380...440VAC.

NOTE: For higher powers and voltages, or suitable for heavy-duty starting (centrifugal fans, mills, crushers) that is with starting time exceeding 12s, consult Customer Service; see contact details on inside front cover.

Components

Starter	Contactors			Thermal overload relay	Time relay	Auxiliary contacts fitted on contactor:			Rigid connections
	Line	Delta	Star			Line	Delta	Star	
BFA009 70	BF09 10A	BF09 01A	BF09 10A	② (RF38)	TM ST②	BFX10 20	—	BFX10 11	BFX31 31
BFA012 70	BF12 10A	BF12 01A	BF09 10A	② (RF38)	TM ST②	BFX10 20	—	BFX10 11	BFX31 31
BFA018 70	BF18 10A	BF18 01A	BF12 10A	② (RF38)	TM ST②	BFX10 20	—	BFX10 11	BFX31 31
BFA025 70	BF25 10A	BF25 01A	BF18 10A	② (RF38)	TM ST②	BFX10 20	—	BFX10 11	BFX31 31
BFA026 70	BF26 00A	BF26 00A	BF18 10A	② (RF38)	TM ST②	BFX10 20	BFX10 11	BFX10 11	BFX32 32
BFA032 70	BF32 00A	BF32 00A	BF25 10A	② (RF38)	TM ST②	BFX10 20	BFX10 11	BFX10 11	BFX32 32
BFA038 70	BF38 00A	BF38 00A	BF25 10A	② (RF38)	TM ST②	BFX10 20	BFX10 11	BFX10 11	BFX32 32
DYF50 E	BF50 00	BF50 00	BF32 00	RF95 3	TM ST②	BFX10 20	BFX10 11	BFX10 11	—
DYF65 E	BF65 00	BF65 00	BF32 00	RF95 3	TM ST②	BFX10 20	BFX10 11	BFX10 11	—
DYF80 E	BF80 00	BF80 00	BF50 00	RF95 3	TM ST②	BFX10 20	BFX10 11	BFX10 11	—
DYF95 E	BF95 00	BF95 00	BF50 00	RF95 3	TM ST②	BFX10 20	BFX10 11	BFX10 11	—
NYF115	B115 00	B115 00	BF65 00	RF200	TM ST②	G350	G354	BFX10 11	—
NYF145	B145 00	B145 00	BF80 00	RF200	TM ST②	G350	G354	BFX10 11	—
NYF180	B180 00	B180 00	B115 00	RF200	TM ST②	G350	G354	G354	—
NYF250	B250 00	B250 00	B145 00	RF420	TM ST②	G350	G354	G354	—
NYF310	B310 00	B310 00	B180 00	RF420	TM ST②	G350	G354	G354	—
NYF400	B400 00	B400 00	B250 00	RF420	TM ST②	G350	G354	G354	—

Reference standards

Compliant with standards: IEC/EN 60947-1, IEC/EN 60947-4-9.

Electromechanical starters

Star-delta starters.

Non-metallic enclosure for starters

Enclosed starters



M3 P...70... - M3 PA70

- 1 Complete order code with the coil voltage digit or the coil voltage digit followed by 60 if 60Hz. Standard voltage are as follows:
- AC 50/60Hz 024 / 048 / 110 / 230 / 400V
- AC 60Hz 024 60 / 048 60 / 120 60 / 220 60 / 230 60 (V).
Example: M3P009 70 024 for M3P009 star-delta starter with 24VAC 50/60Hz power supply.
M3P009 70 02460 for M3P009 star-delta starter with 24VAC 60Hz power supply.
- 2 The thermal overload relay is not included and must be purchased separately. Choose the thermal relay adjustment range considering a value equal to 58% of rated motor current (Ie).
Example: Ie=10A; 58% Ie = 5.8A. The suitable relay range is 4-6.5A, set at 5.8A, so the order code to select is RF380650).
Refer to page 3-4 for the order codes available.
- 3 Suitable for BFA...70 starters.
- 4 TM ST with auxiliary supply 24...240VAC;
TM ST A440 with auxiliary supply 380...400VAC.

NOTE: For higher powers and voltage ratings or suitable for heavy-duty starting (centrifugal fans, mills, crushers) that is with starting time exceeding 12s, consult Customer Service; see contact details on inside front cover.

Order	Three-phase motor control. Max IEC operating current (≤440V)	Qty per pkg	Wt
	[A]	n°	[kg]

Star-delta starters in enclosure with Start and Stop/Reset buttons. Starting time up to 12 seconds and a maximum of 30 operations/hour.

M3 P009 70	16	1	3.540
M3 P012 70	22	1	3.540
M3 P018 70	28	1	3.540
M3 P025 70	35	1	3.650
M3 P026 70	43	1	3.650
M3 P032 70	50	1	3.800
M3 P038 70	60	1	3.800

With switch disconnecter, rotary door-coupling handle GAX61 and Start and Stop/Reset buttons.

M3 P009 73	16	1	3.700
M3 P012 73	22	1	3.700
M3 P018 73	28	1	3.700
M3 P025 73	35	1	3.800
M3 P026 73	43	1	3.800
M3 P032 73	50	1	4.300
M3 P038 73	60	1	4.300

Enclosure for star-delta starter, complete with Start and Stop/Reset buttons, metal plate fixed with piece of 35mm DIN (IEC/EN 60715) rail.

M3 PA70	—	1	2.240
---------	---	---	-------

Operational characteristics

IEC standard motor powers

230V [kW]	400V [kW]	440V [kW]	500V [kW]
4	7.5	7.5	7.5
5.5	11	11	11
7.5	15	11	11
11	18.5	18.5	22
11	22	22	25
15	25	25	25
15	30	30	30

- Cable entry: Smooth surface; can be drilled by customer
- Ambient conditions:
 - Operating temperature: -25...+60°C
 - Storage temperature: -40...+70°C
- Degree of protection: IEC IP65 for M3P...; UL Type 1, 12, 4/4X for M3...UL versions.

Special M3... versions

In addition to standard-indicated versions, cULus certified starters are available up to 52A motor control rating max. This is also valid for the enclosure with general use rating of 65A.

Add suffix **UL** to the order code, e.g. M3 PA70UL.

Certifications and compliance

Certifications obtained: UL Listed, for USA and Canada (File E93602), as Magnetic Motor Controllers - Enclosed (starters) and - Enclosures for M3...PUL types. Compliant with standards: IEC/EN 60947-1, IEC/EN 60947-4-1, UL508, CSA C22.2 n° 14 for starters; UL 508A for M3P A70UL.

Maximum available space inside M3P... star-delta starters and M3 PA70 enclosure

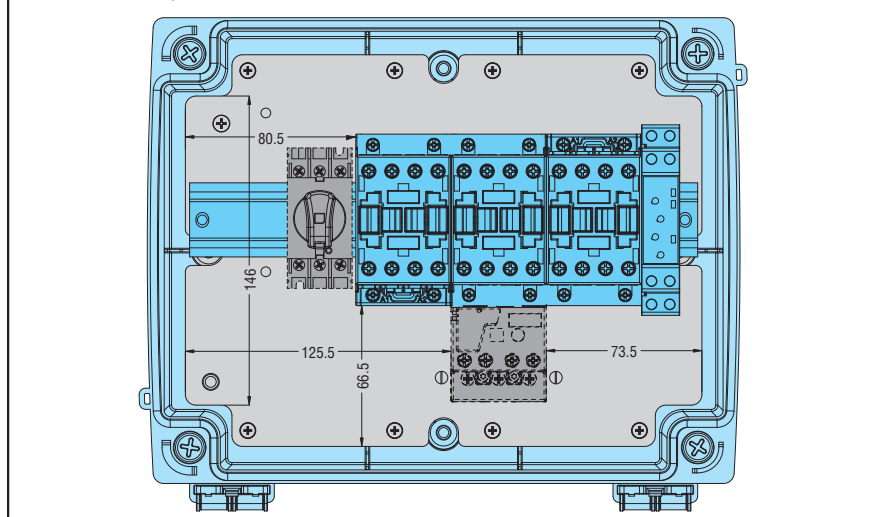

Components

Type	Enclosure	Contactors			T/o relay e	Time relay	Auxiliary contacts fitted on contactor:			Rigid connections	Switch disconnecter
		Line	Delta	Star			Line	Delta	Star		
M3P009 70	M3 PA70	BF09 10A	BF09 01A	BF09 10A	(RF38)	TM ST	BFX10 20	—	BFX10 11	BFX31 31	GA016 A
M3P012 70	M3 PA70	BF12 10A	BF12 01A	BF09 10A	(RF38)	TM ST	BFX10 20	—	BFX10 11	BFX31 31	GA025 A
M3P018 70	M3 PA70	BF18 10A	BF18 01A	BF12 10A	(RF38)	TM ST	BFX10 20	—	BFX10 11	BFX31 31	GA032 A
M3P025 70	M3 PA70	BF25 10A	BF25 01A	BF18 10A	(RF38)	TM ST	BFX10 20	—	BFX10 11	BFX31 31	GA040 A
M3P026 70	M3 PA70	BF26 00A	BF26 00A	BF18 10A	(RF38)	TM ST	BFX10 20	BFX10 11	BFX10 11	BFX32 32	GA063 SA
M3P032 70	M3 PA70	BF32 00A	BF32 00A	BF25 10A	(RF38)	TM ST	BFX10 20	BFX10 11	BFX10 11	BFX32 32	GA063 SA
M3P038 70	M3 PA70	BF38 00A	BF38 00A	BF25 10A	(RF38)	TM ST	BFX10 20	BFX10 11	BFX10 11	BFX32 32	GA063 SA

Electromechanical starters

Empty non-metallic enclosures

Accessories and spare parts

Empty enclosures

4



M...PA



M...RA



M...N

new

new

new

Order code	Contactor type ①	Thermal relay ②	Degree of protect.	Qty per pkg n°	Wt [kg]
Enclosures with Start-Stop/Reset pushbuttons.					
M0PA	BG06, BG09, BG12	RF9	IP65	1	0.490
M1PA	BF09A, BF12A, BF18A	RF38	IP65	1	0.545
M2PA	BF25A, BF26A, BF32A	RF38	IP65	1	0.715
M25PA	BF38A	RF38	IP65	1	0.990
M3PA	BF50, BF65, BF80, BF95, BF110	RF95 3	IP65	1	1.900
Enclosures with Reset pushbutton.					
M0RA	BG06, BG09, BG12	RF9	IP65	1	0.445
M1RA	BF09A, BF12A, BF18A	RF38	IP65	1	0.500
M2RA	BF25A, BF26A, BF32A	RF38	IP65	1	0.670
M25RA	BF38A	RF38	IP65	1	0.970
M3RA	BF50, BF65, BF80, BF95, BF110	RF95 3	IP65	1	1.850
Enclosures without external pushbuttons.					
M0N	BG06, BG09, BG12	RFA9	IP65	1	0.405
M1N	BF09A, BF12A, BF18A	RF38	IP65	1	0.460
M2N	BF25A, BF26A, BF32A	RF38	IP65	1	0.640
M24N	BG.../BF09A...BF25A	②	IP65	1	0.625
M25N	BF38A	RF38	IP65	1	0.940
M3N	BF50, BF65, BF80, BF95, BF110	RF95 3	IP65	1	1.800

- ① To be purchased separately; refer to page 2-4 for contactor choice.
- ② To be purchased separately. Refer to pages 3-2 to -6 for thermal overload relay choice. For use of the overload relay in the M24N, consult Customer Service; see contact details on inside front cover.
- ③ Reversing contactor assemblies BGR..., BGT..., BFA...42 and changeover types BGC... can also be fitted in M24N and M25... types. See pages 4-4, 4-13 and 4-15.
- ④ MX 31 metal mounting plate included.
- ⑤ MX 30 metal mounting plate included.
- ⑥ To install eventual pushbuttons, selectors and/or other control accessories, use the PLatinum series and mount the relay contact elements on the cover using the LPX AU120 mounting adapter. See section 7.

Enclosure type	Maximum operating current (≤440V) A
M0...	12
M1...	18
M2...	32
M24N	38
M25...	38
M3...	110

General characteristics
Enclosures are supplied with the following accessories:

Accessory	Type	Type of enclosure							
		M0 PA	M1 PA	M2 PA	M25 PA	M0 RA	M1 RA	M2 RA	M25 RA
Description	Type								
Contact holder	MX 20P MX 21P	1							
Buttons: - Start/Reset - Start	LPC B1176 LPC B2104 LPC B1113					1	1	1	1
Contact for Start button	LPX C10	1	1	1	1				
Stop/Reset button extension	MX 10P MX 11P MX 12P	1					1		
Unused hole threaded plug	MX 01						1	1	1

- M3 PA enclosure: 2 Start and Stop/Reset pushbuttons, 2 G285 auxiliary terminals and 1 MX30 mounting plate
- M3 RA enclosure: 1 Reset pushbutton, 2 G285 auxiliary terminals and 1 MX30 mounting plate
- M3N enclosure: Supplied without accessories to be purchased separately including MX 30 mounting plate.

- Enclosures can house the following devices:
- M0 = BG... with/without RF9
 - M1 = BF09A-BF12A-BF18A with/without RF38
 - M2 = BF25A-BF26A-BF32A, assemblies BFA...42 with/without RF38
 - M24N = BF25A-BF26A-BF32A, assemblies BGR/BGT/BGC and BFA...42 without overload
 - M25 = BF26...BF38A, assemblies BGR/BGT/BGC and BFA...42 with/without overload
 - M3 = BF50...BF110 and all assemblies with/without overload.

- Operational characteristics:**
- Cable entry:
 - M0/M1/M2... - 2 knockouts PG13.5/M20 on enclosure top and bottom
 - M24N/M25... - 2 knockouts PG16/M25-PG29/M32 on enclosure top and bottom
 - M3... - Smooth surfaces; can be drilled by customer
 - Ambient conditions:
 - Operating temperature: -25...+60°C
 - Storage temperature: -40...+70°C
 - Degree of protection: IEC IP65 for all; UL Type 1, 12, 4/4X for M0/M1/M2/M24N/M25... types and M3...UL versions.

Special M3... versions
In addition to standard-indicated versions, cULus certified starters and enclosures are available up to 52A - motor control and 65A general use rating max (MX30 plate, earth/ground and neutral terminal plates are always included in this case).
Add suffix **UL** to the order code of enclosures e.g. M3N **UL**.

Certifications and compliance
Certifications obtained: EAC for all; for M3NUL type, UL Listed for USA and Canada (cULus - File E300050) as Industrial control panels; for M0/M1/M2PA/RA/N and other M3...UL types, UL Listed for USA and Canada (cULus - File E93602) under magnetic motor controllers as Polymeric enclosures - and CSA certified for Canada and USA (cCSAus - File 94157) as Non-metallic enclosures. UL/CSA pending for M24N and M25... types. Compliant with standards: IEC/EN 60947-1, IEC/EN 60947-4-1, UL 508, CSA CS22.2 n°14; UL 508A and CSA C22.1 for M3NUL type.

Accessories and spare parts

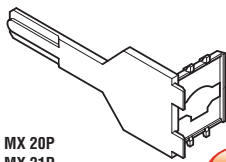

MX 20P
MX 21P

new

new

Order code	Description	Qty per pkg n°	Wt [kg]
MX 01	Threaded plug for unused holes, grey RAL7035	10	0.007
MX 10P	Stop/Reset button extension rod for M0 enclosure	5	0.010
MX 11P	Stop/Reset button extension rod for M1 enclosure	5	0.010
MX 12P	Stop/Reset button extension rod for M2 enclosure	5	0.010
MX 20P	Mounting base for LPX C... contact on M0 enclosure	5	0.014
MX 21P	Mounting base for LPX C... contact on M1, M2, M25 enclosure	5	0.014
MX 30	Metal mounting plate for M3N	1	0.500
MX 31	Metal mounting plate for M24N and M25 enclosures	1	0.400

Electromechanical starters

Empty non-metallic enclosures

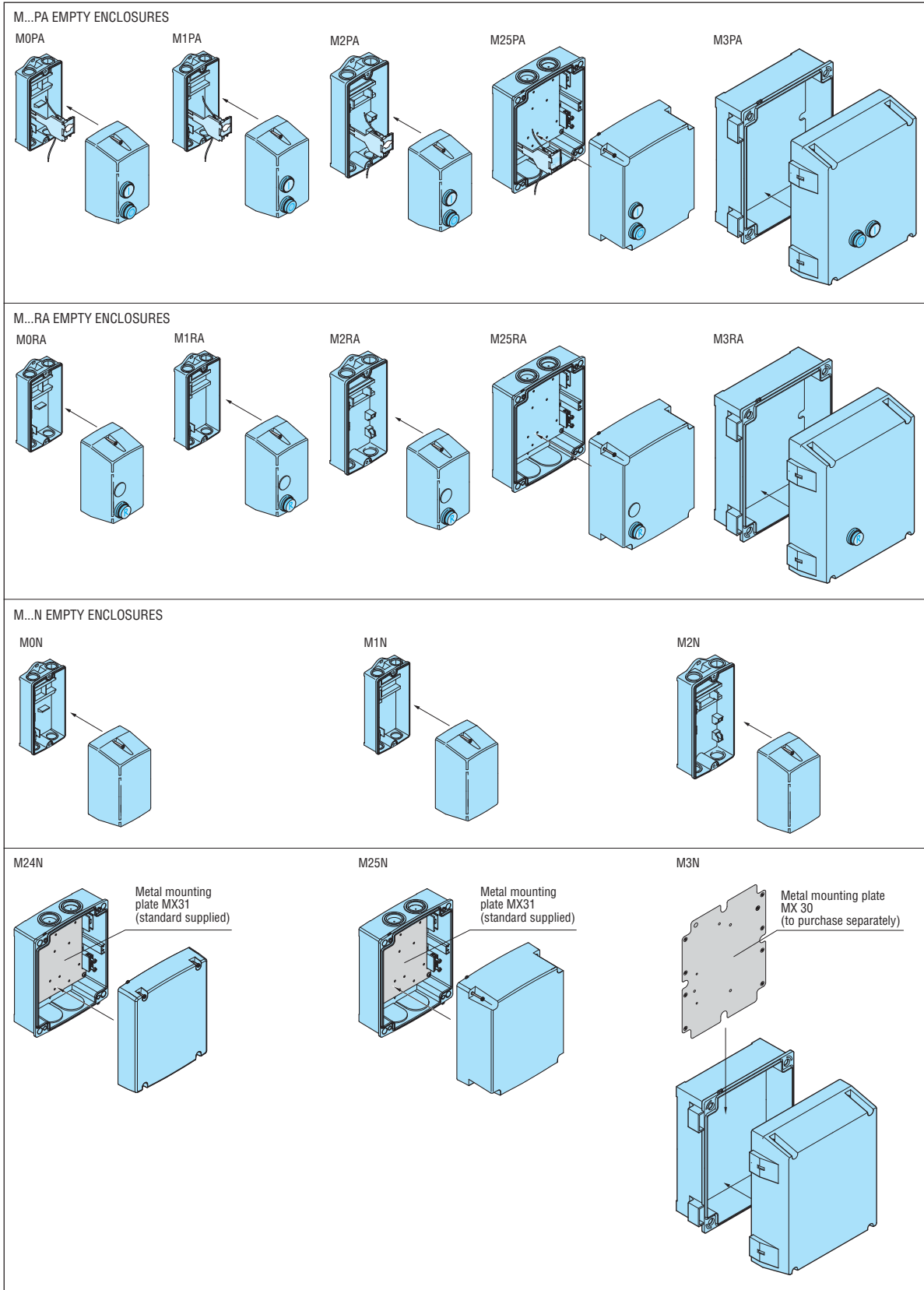

4

Dimensions
pages 4-16 and 17

Wiring diagrams
page 4-20

4-9

Electromechanical starters

Direct-on-line starters - Full voltage across the line.

Non reversing three phase

4

M...P... STARTERS, ENCLOSED

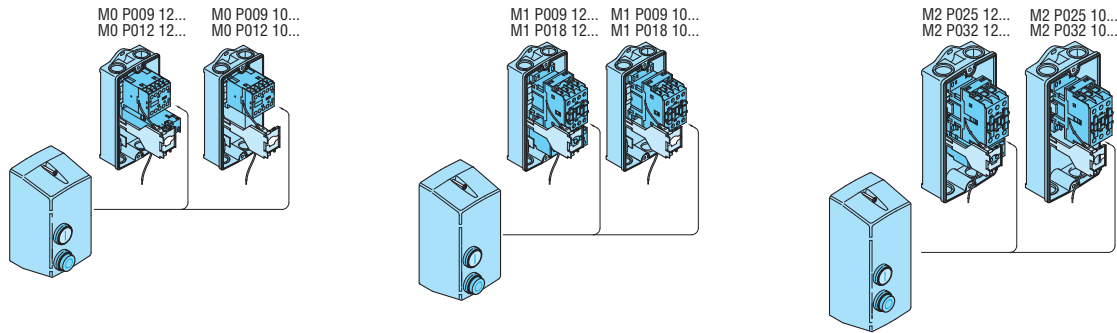

M...R... STARTERS, ENCLOSED

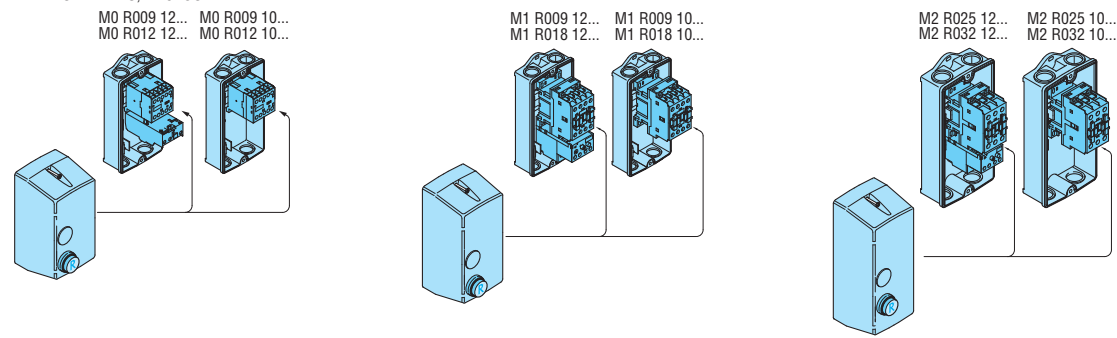

M25... STARTERS, ENCLOSED

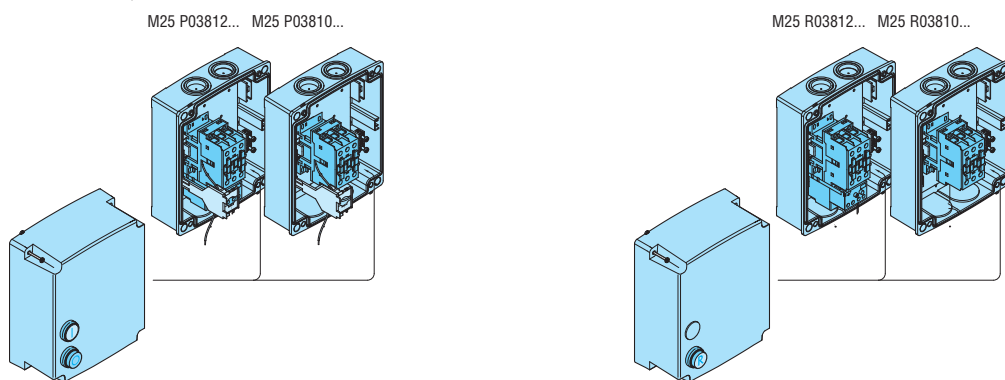

M3... STARTERS, ENCLOSED

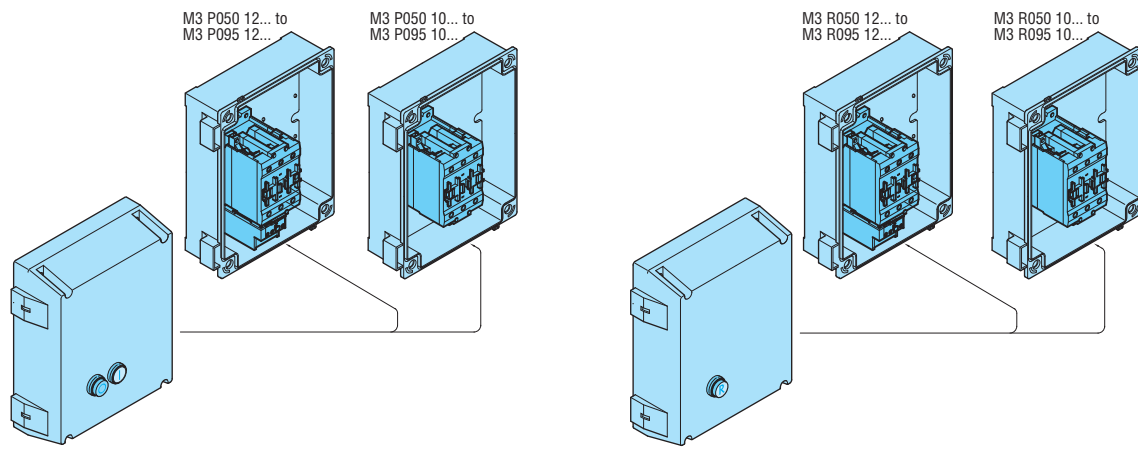

Electromechanical starters

Direct-on-line starters - Full voltage across the line. Accessories and spare parts

Maximum combinations for M0... and M1... starters in enclosure

For the fitting of add-on blocks and electronic relays in the starters, consult our Customer Service; see contact details on inside front cover.

The enclosure cover can be equipped with various types of actuators and pilot lights, per following details:

1) Upper position 1

The cover must be drilled in this position, with a 22.5mm hole, by the user and LPL... or 8 LP2T IL...P pilot light can be fitted.

To fit the LPL... (not type 8 LP2T IL...P) pilot light head, the mounting base, type MX 20P for M0 enclosure or type MX 21P for M1 enclosure, must also be purchased. The LED element is snapped onto this mounting base.

No adapter or base is needed for 8 LP2T IL...P and 8 LP2T Z...

2) Middle position 2

Based on the enclosure type, in this position, the user finds either the Start button or threaded plug. Various **PLatinum** actuators can be fitted in this position, such as flush or extended buttons, selectors or pilot lights, as illustrated below.

To fit the actuators (not required for 8 LP2T IL...P pilot lights), the mounting base, type MX 20P for M0 enclosure, or type MX 21P for M1 enclosure, must also be purchased. The contact or LED elements are snapped onto this mounting base.

No adapter or base is needed for 8 LP2T IL...P and 8 LP2T Z...

3) Lower position 3

The STOP/RESET button is mounted in this position, except for the enclosure without buttons.

This button activates the thermal overload relay via a mechanical actuator.

In eventual applications without thermal overload relay, this button can be removed and the hole closed up by the threaded plug MX 01.

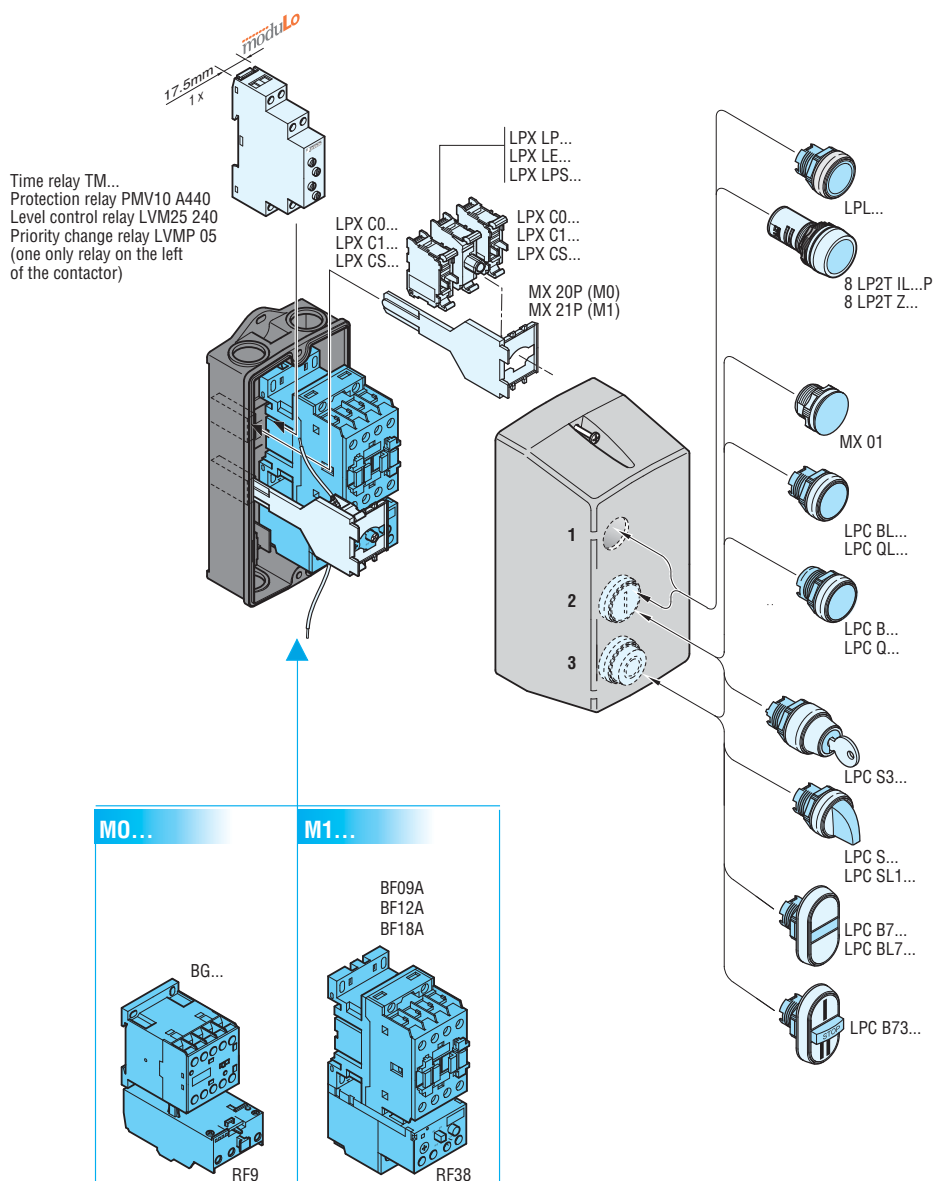

Electromechanical starters

Direct-on-line starters - Full voltage across the line.

Accessories and spare parts

4

Maximum combinations for M2... starters in enclosure

For the fitting of add-on blocks and electronic relays in the starters, consult our Customer Service; see contact details on inside front cover.

The enclosure covers can be equipped with various types of actuators and pilot lights, per following details:

- Upper position 1**
The cover must be drilled in this position with a 22.5mm hole by the user; LPL... or 8 LP2T IL...P pilot light can be fitted.
To fit the LPL... pilot light, the mounting base type MX 21P must also be purchased. The LED element is snapped onto this mounting base.
No adapter or base is needed for 8 LP2T IL...P and 8 LP2T Z...

- Middle position 2**
Based on the enclosure type, in this position, the user finds either the Start button or threaded plug.
Various **PLatinum** actuators can be fitted in this position, such as flush or extended buttons, selectors or pilot lights, as illustrated in the side figure.
To fit the actuators (not required for 8 LP2T IL...P pilot light), the mounting base type MX 21P must also be purchased.
The contact or LED elements are snapped onto this mounting base.
No adapter or base is needed for 8 LP2T IL...P and 8 LP2T Z...
- Lower position 3**
The STOP/RESET button is mounted in this position, except for the enclosure without buttons.

This button activates the thermal overload relay via a mechanical actuator. In eventual applications without thermal overload relay, this button can be removed and the hole closed up by the threaded plug MX 01. Various **PLatinum** actuators can be fitted in this position, such as flush or extended buttons, selectors or pilot lights, as illustrated in the drawing below. To fit the actuators (not required for 8 LP2T IL...P pilot light), the mounting base type MX 21P must also be purchased. The contact or LED elements are snapped onto this mounting base. No adapter or base is needed for 8 LP2T IL...P and 8 LP2T Z...

- Upper position 4**
The cover must be drilled in this position with a 22.5mm hole by the user whenever an external handle is needed for a switch disconnecter fitted in the enclosure.

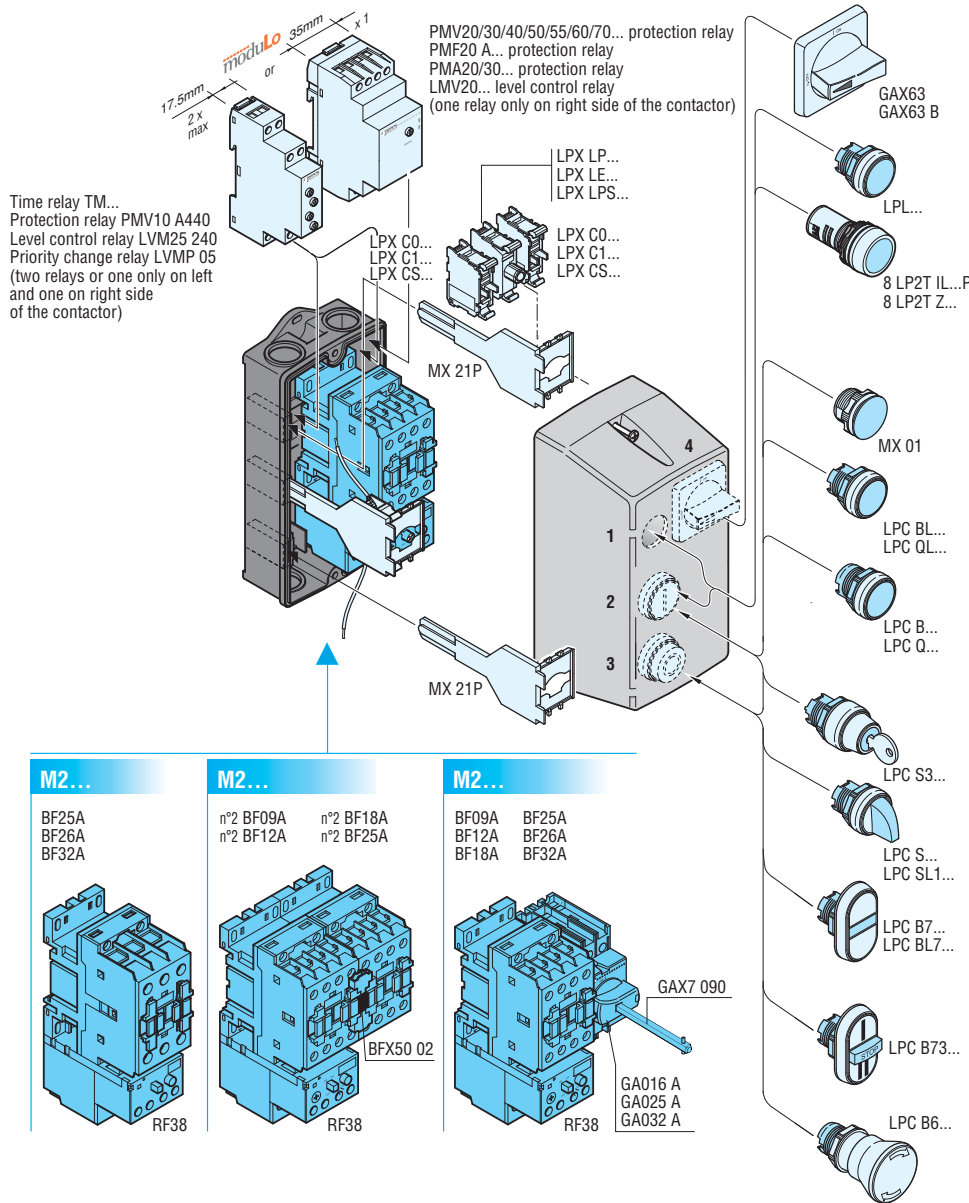

Electromechanical starters

4

Maximum combinations for starters in M24N enclosure

In addition to a direct-on-line, full voltage across the line, starter or reversing contactor assembly, various other electromechanical devices can be fitted. The cover of the M24N enclosure can be used across the entire surface to mount pushbuttons, measuring instruments, switch disconnectors GA016A...GA032A type. No contact blocks or other additional accessories can be mounted on the contactor face of AC BF series; they can only be fitted on the contactor side since the cover is shallow. Eventually pushbuttons, selector switches and/or other control accessories of the **PLatinum** series can be used and contact or LED elements can be mounted directly inside on the cover with the LPX AU120 mounting adapter; refer to section 7.

MX 31 internal metal mounting plate is standard-supplied.

The wall fixing holes and the cover closing captive screws are positioned **outwards** with respect to the sealing gasket. This guarantees the protection degree of the enclosure against infiltrations liquid (IEC IPX5 / UL Type 4X).

The base has **ribbing** which facilitates the fixing of DIN rails, metal mounting plates and electronic printed boards.

Grid references, marked by letters and numbers, are engraved on the interior surface of the cover. This grid allows to quickly identify the exact drilling points where pushbuttons, handles or pilot lights will be mounted.

A **safety sealing** system keeps the cover and base together to avoid inopportune opening and tampering.

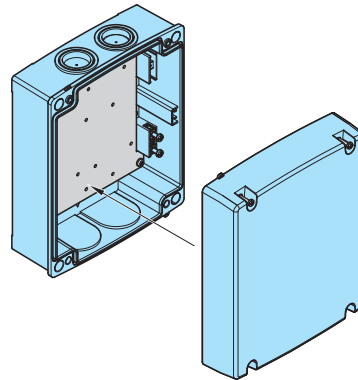
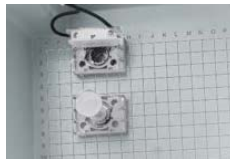
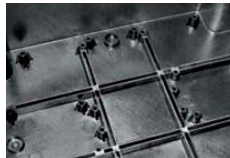

Available space for fitting other electrical or electronic devices

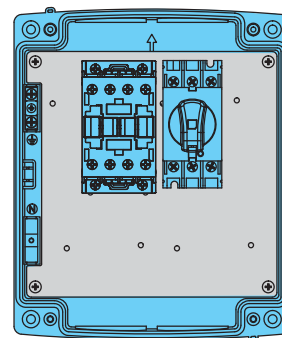
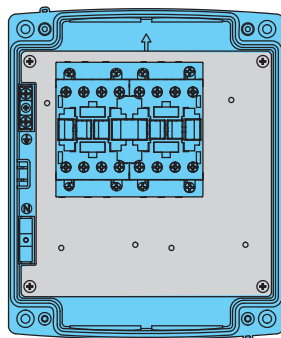
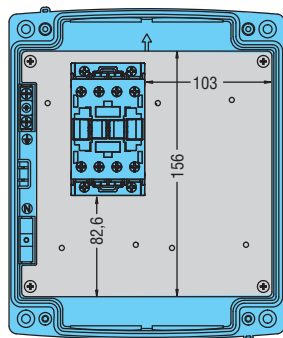

M24N
BG06
BG09
BG12
without overload

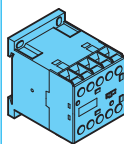

M24N
BF09A...BF25A
without overload

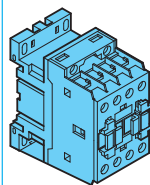

M24N
BGR... - BGT... - BGC... without overload
n° 2 BF09A n° 2 BF12A
n° 2 BF18A n° 2 BF25A
All without overload
BFA...42 without overload

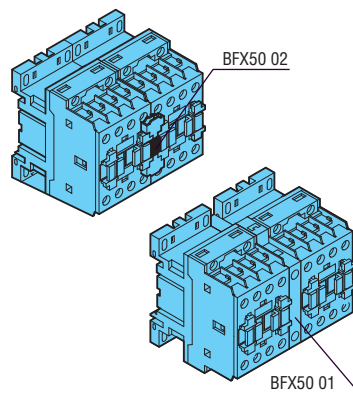

M24N
BF09A BF12A
BF18A BF25A
with GA016A...GA032A

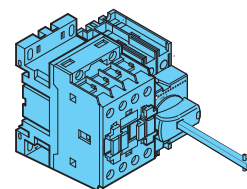

Electromechanical starters

Maximum combinations for starters in M25... enclosure

In addition to a direct-on-line, full voltage across the line, starter or reversing contactor assembly, various other electromechanical devices can be fitted. The cover of the M25 enclosure can be used across the entire surface to mount pushbuttons, measuring instruments, switch disconnectors GA016A...GA040A type. Possible contact blocks or other additional accessories can be mounted on the contactor face of AC or DC BF series or on the contactor side since the cover is deep. Eventually pushbuttons, selector switches and/or other control accessories of the **PLatinum** series can be used and contact or LED elements can be mounted directly inside on the cover with the LPX AU120 mounting adapter; refer to section 7.

MX 31 internal metal mounting plate is standard-supplied.

4

The wall fixing holes and the cover closing captive **screws** are positioned **outwards** with respect to the sealing gasket. This guarantees the protection degree of the enclosure against liquid infiltrations (IEC IPX5 / UL Type 4X).

The base has **ribbing** which facilitates the fixing of DIN rails, metal mounting plates and electronic printed boards.

Grid references, marked by letters and numbers, are engraved on the interior surface of the cover. This grid allows to quickly identify the exact drilling points where pushbuttons, handles or pilot lights will be mounted.

A **safety sealing** system keeps the cover and base together to avoid inopportune opening and tampering.

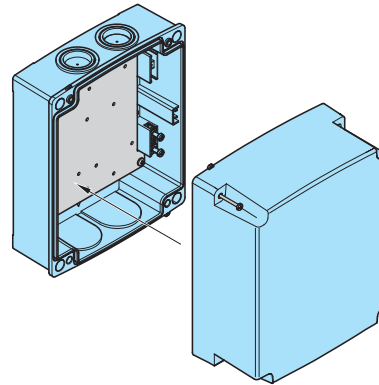
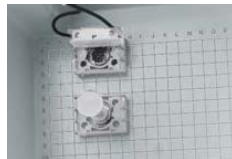

Available space for fitting other electrical or electronic devices

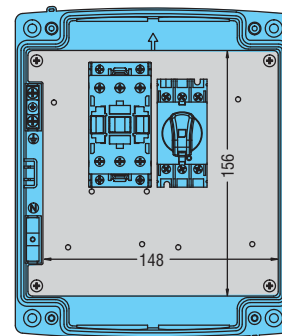
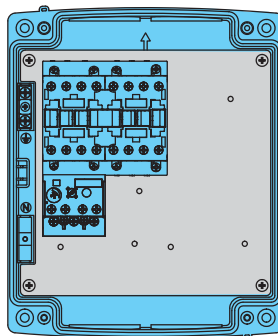
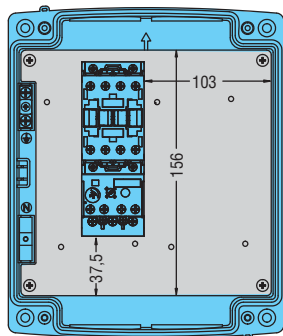

M25...038...

BF38
with or without
overload

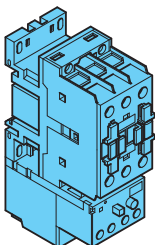

RF38...

M25...

BF26 - BF32
with or without
overload

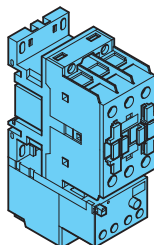

RF38...

M25...

BGR... - BGT... - BGC with or without overload RF9
n° 2 BF26 - n° 2 BF32 - n° 2 BF38 with or without
overload RF38
BFA...42 with or without overload RF38

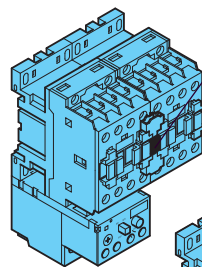

RF38...

BFX50 02

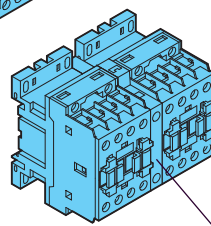

BF09A...BF38A with
BFX50 01

M25...

BF09 BF12 BF18
BF26 BF32 BF38
with GA016A...GA040A

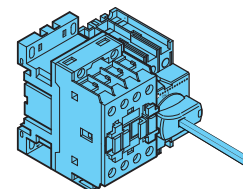

Electromechanical starters

Direct-on-line starters

Maximum combinations for starters in M3... enclosure

In addition to a direct-on-line, full voltage across the line, starter or reversing contactor assembly, star-delta starters can be installed as illustrated at the lower right as well as various other electromechanical devices. The cover of the M3 enclosure can be used across the entire surface to mount pushbuttons, measuring instruments or switch disconnectors GA016A...GA125A, etc.

MX 30 internal metal mounting plate is standard supplied with M3P... and M3R... types; not included with the M3N, it can be purchased separately.

With the specifically designed **hinges**, the cover remains attached to the base, fully open, while the wiring work is being carried out. By applying **slight pressure** on the hinges, the cover can be released from the base.

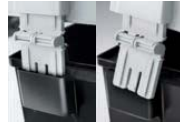

The cover closing captive **screws** and the wall fixing holes are positioned **outwards** with respect to the sealing gasket. This guarantees the protection degree of the enclosure against liquids infiltrations (IEC IPX5 / UL Type 4X).



A **safety sealing** system keeps the cover and base together to avoid inopportune opening and tampering.



Grid references, marked by letters and numbers, are engraved on the interior surface of the cover. This grid allows to quickly identify the exact drilling points where pushbuttons, handle or pilot lights will be mounted.



A properly predrilled metal mounting plate (MX 30 standard supplied except for M3N) permits to quickly and precisely fix equipment in place.



The base has **ribbing** which facilitates the fixing of DIN rails, metal mounting plates and electronic printed boards.

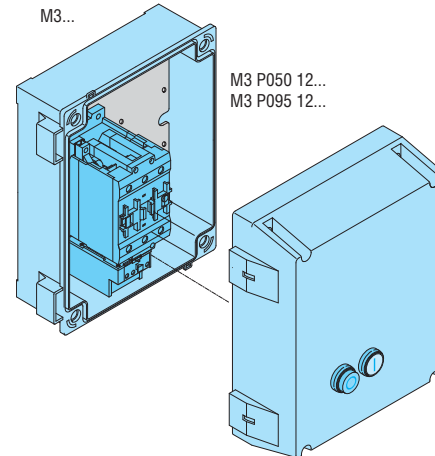

Available space for fitting other electrical or electronic devices

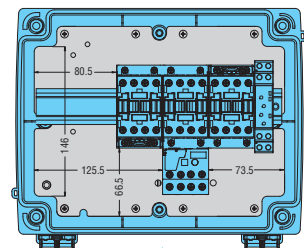
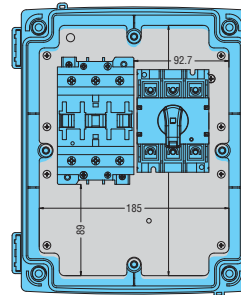
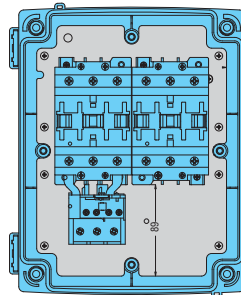
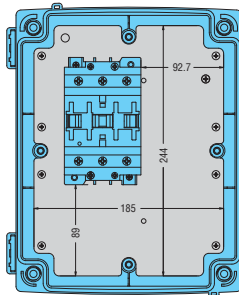

M3...

n° 1 BF50 n° 1 BF95
n° 1 BF65 n° 1 BF110
n° 1 BF80

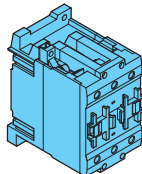

M3...

n° 2 BF50 n° 2 BF65 n° 2 BF95
n° 2 BF80 n° 2 BF110

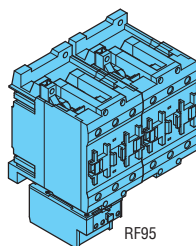

M3...

n° 1 BF50 n° 1 BF65 n° 1 BF95 + n° 1 GA...
n° 1 BF80 n° 1 BF110

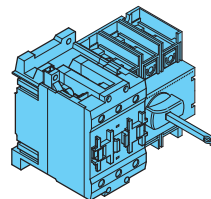

M3P...70

Star-delta combinations with t/o relay RF38, TM ST timer and contactors: BF09A BF12A BF18A BF25A BF26A BF38A

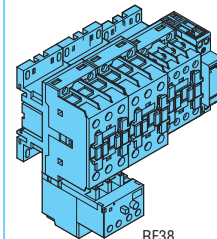

Electromechanical starters

Dimensions [mm (in)]

DIRECT-ON-LINE STARTERS - EMPTY ENCLOSURES

M0

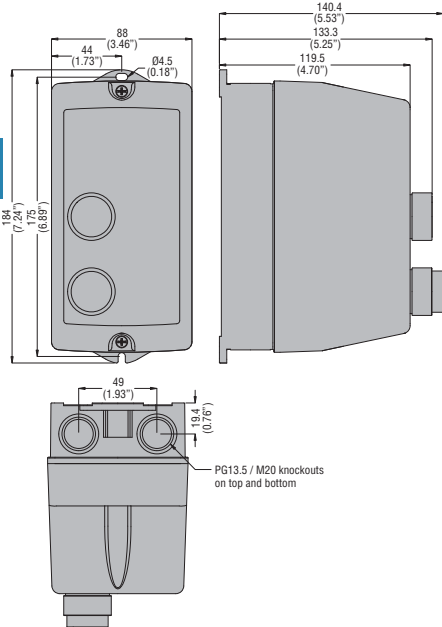

M1

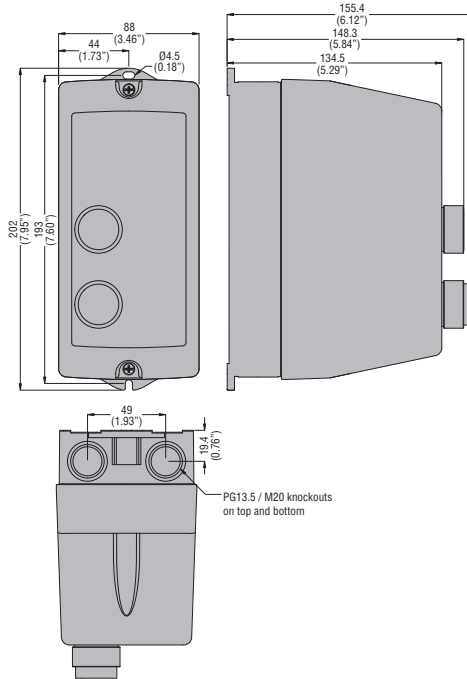

M2

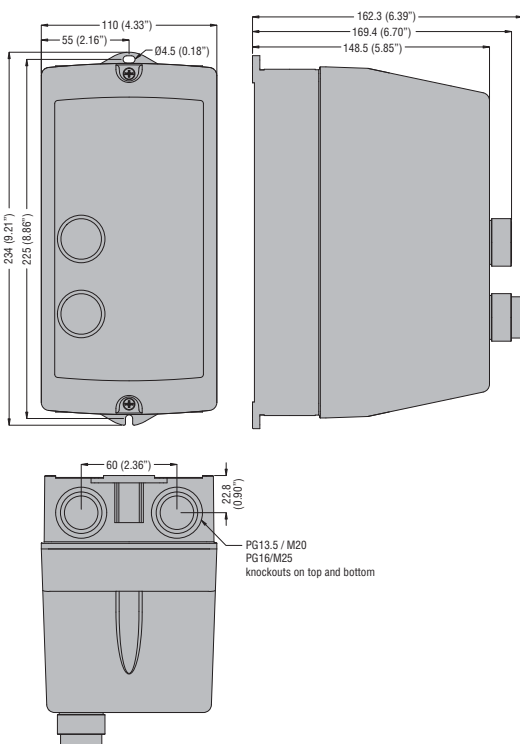

M24N

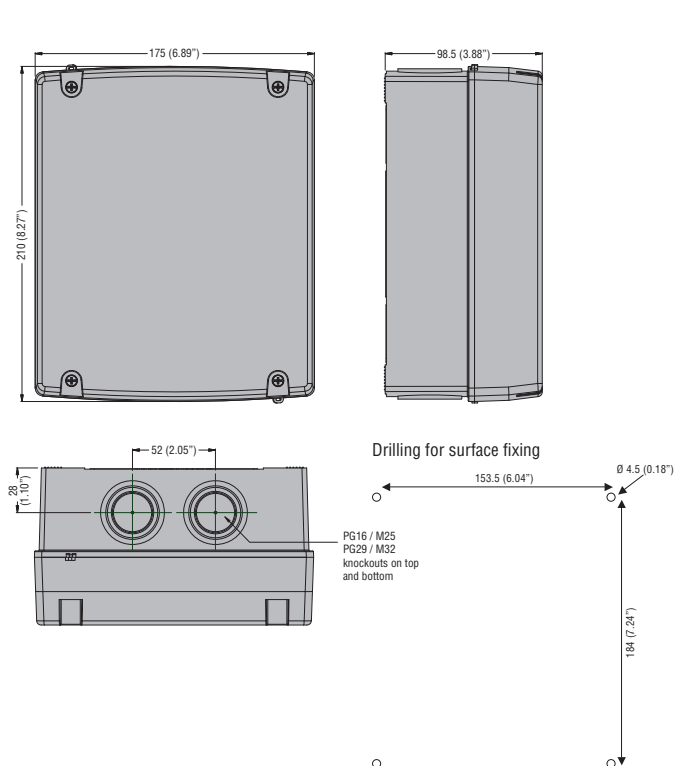

Electromechanical starters

Dimensions [mm (in)]

M25

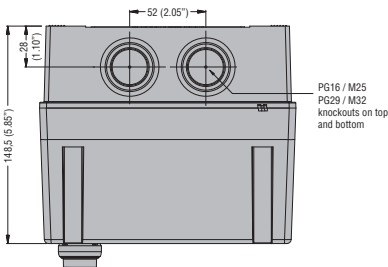
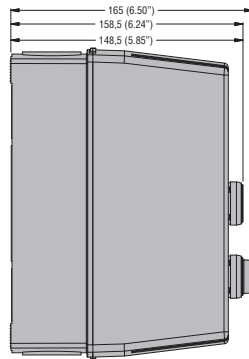
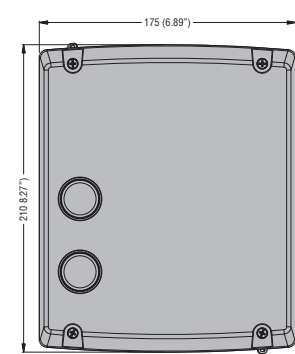

Drilling for surface fixing

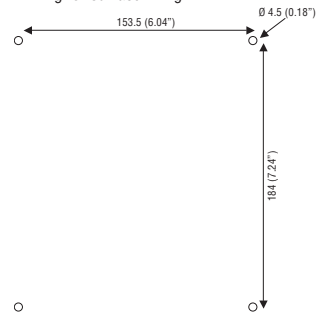

4

M3

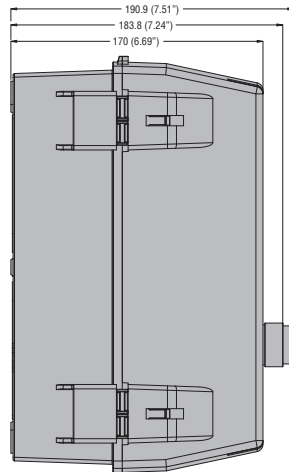
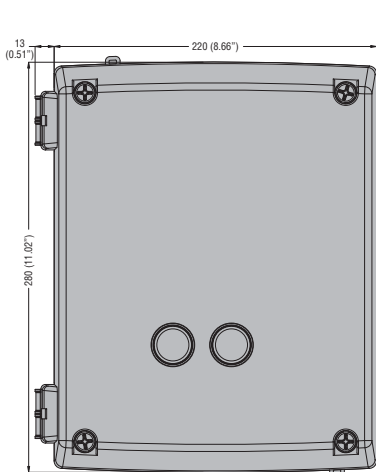

Drilling for surface fixing

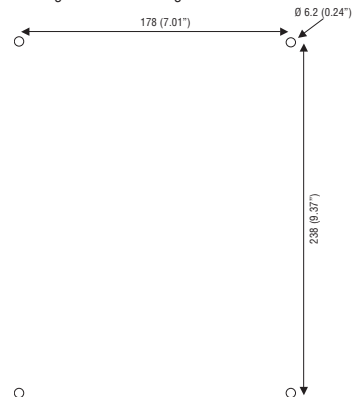

REVERSING CONTACTOR ASSEMBLIES

BGR... with external interlock

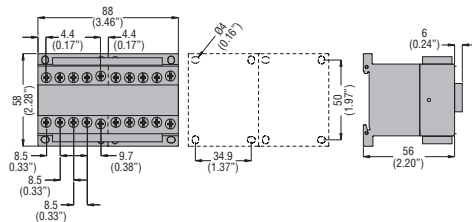

BGT... with internal interlock

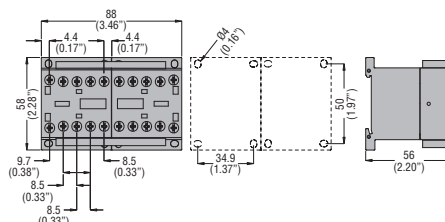

BGTP... with rear PCB solder pins and internal interlock

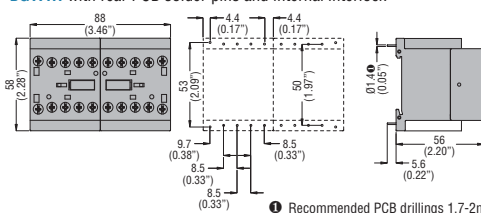

BFA...42 with external interlock

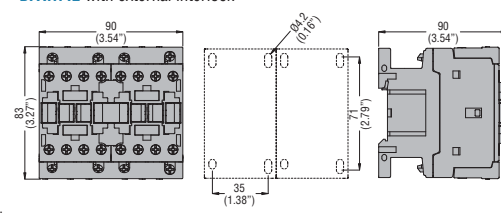

Recommended PCB drillings 1.7-2mm (0.07-0.08").

Electromechanical starters

Dimensions [mm (in)]

CHANGEOVER CONTACTOR ASSEMBLIES

BGC09 T4... with internal interlock

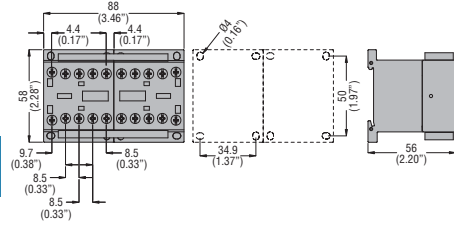

STAR-DELTA STARTERS OPEN FRAME

BFA... 70... on 35mm DIN rail, without thermal overload relay

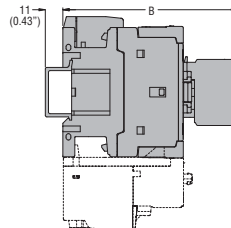
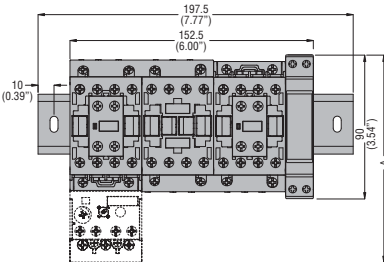

STARTER TYPE	A	B
BFA009 70	130.5 (5.14")	109.5 (4.31")
BFA012 70	130.5 (5.14")	109.5 (4.31")
BFA018 70	130.5 (5.14")	109.5 (4.31")
BFA025 70	130.5 (5.14")	109.5 (4.31")
BFA026 70	135 (5.14")	119 (4.68")
BFA032 70	135 (5.14")	119 (4.68")
BFA038 70	135 (5.14")	119 (4.68")

DYF... on mounting plate, with thermal overload relay

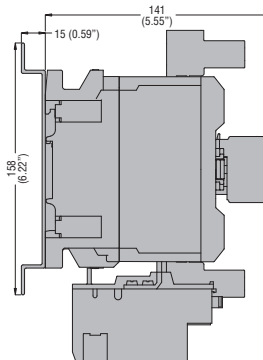
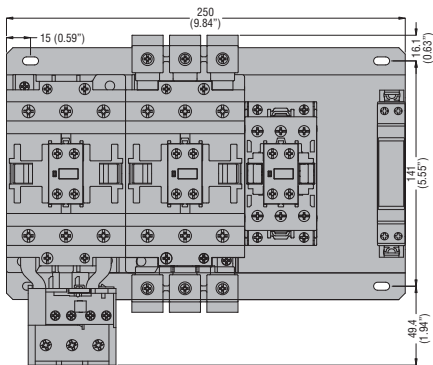

NYF... on mounting plate, with thermal overload relay

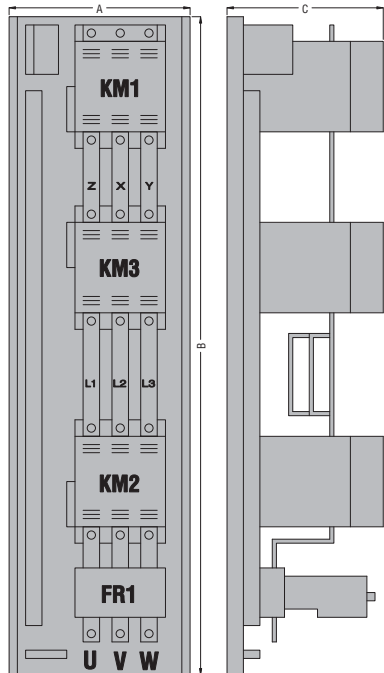

STARTER TYPE	A	B	C
NYF115	340 (13.38")	870 (34.25")	195 (7.68")
NYF145	340 (13.38")	870 (34.25")	195 (7.68")
NYF180	340 (13.38")	870 (34.25")	195 (7.68")
NYF250	440 (17.32")	1000 (39.37")	235 (9.25")
NYF310	440 (17.32")	1000 (39.37")	235 (9.25")
NYF400	440 (17.32")	1000 (39.37")	235 (9.25")

Electromechanical starters

Dimensions [mm (in)]

STAR-DELTA STARTERS IN ENCLOSURE - EMPTY ENCLOSURE FOR STAR-DELTA STARTERS
M3P...70 - M3 PA70

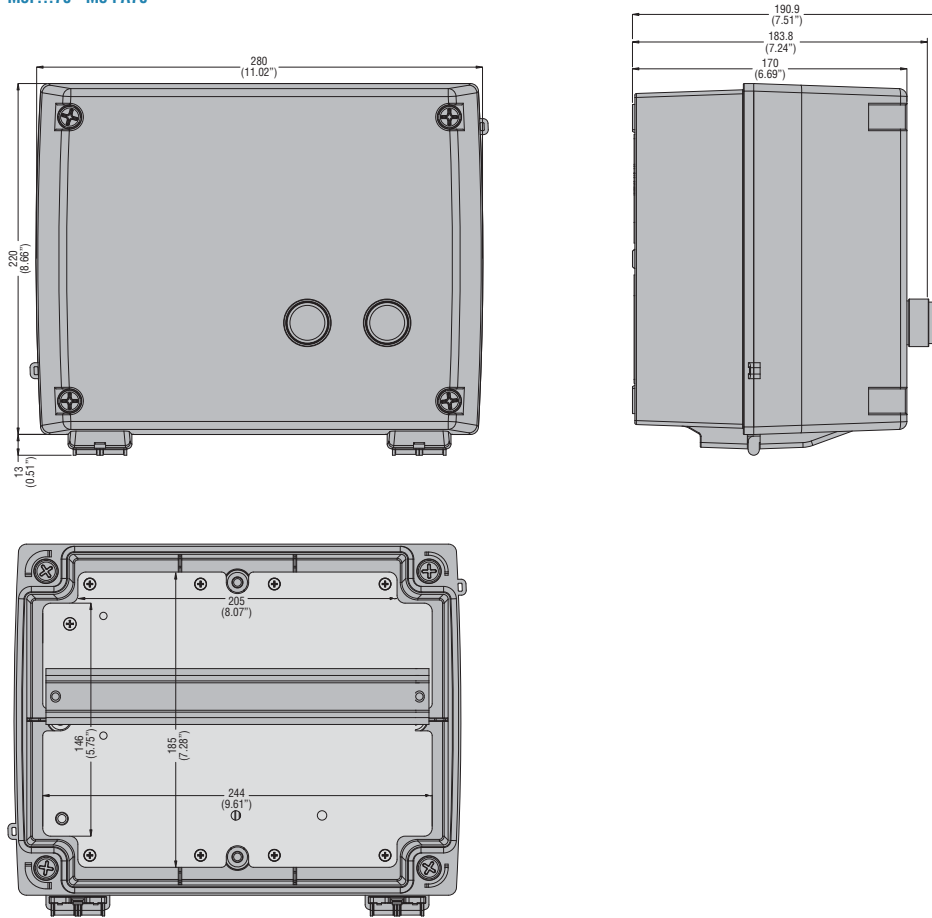

4

Electromechanical starters

Wiring diagrams

4

DIRECT-ON-LINE STARTERS IN ENCLOSURE

M...P

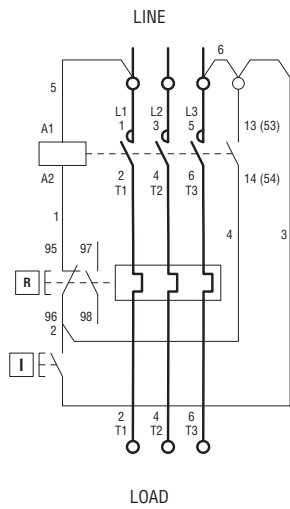

Diagram 1 - Incorporated button control

M...R

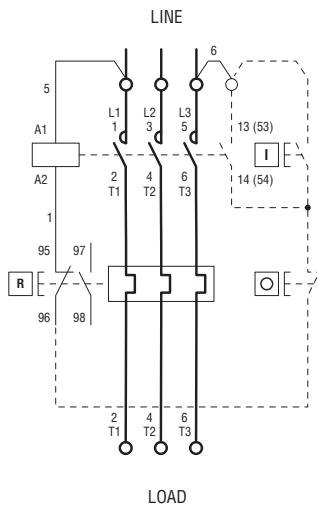

Diagram 2 - External button control

LINE

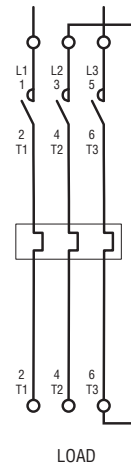

Diagram 3 - Power connection for 1-phase motors

DIAGRAM 2

Connect the eventual two-wire control (e.g. automation) between terminal 3 of the contactor and terminal 96 of the thermal overload relay.

IMPORTANT

- Remove jumpers 5 and 6 and connect the auxiliary line to terminals A1 and .3 for a control circuit with a voltage value different than the supply.
- Remove jumper 5 and connect the neutral to terminal A1 for a control circuit between phase and neutral.
- SINGLE-PHASE SUPPLY
The main circuit must be configured according to Diagram 3 in the case of a single-phase line or motor.
- FUSES
A set of three fuses must be connected upstream of the starter in the event no appropriate protection is included in the system.

REVERSING CONTACTOR ASSEMBLY

BGR...

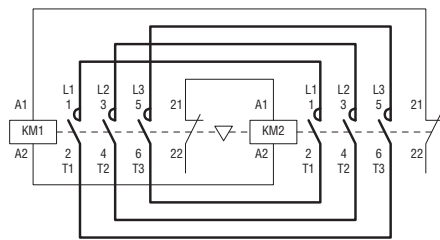

BGT...

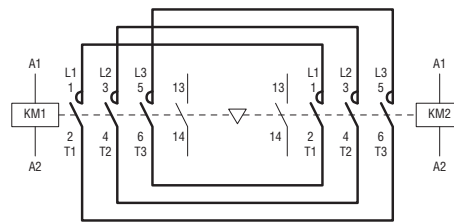

BFA...42

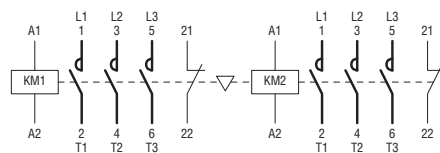

BGTP09...

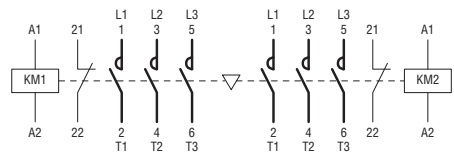

CHANGEOVER CONTACTOR ASSEMBLY

BGC09...

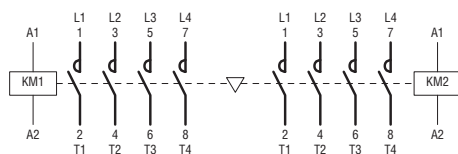

Electromechanical starters

Wiring diagrams

STAR-DELTA STARTERS, OPEN FRAME AND ENCLOSED
BFA009...039 - M3P009...038 70

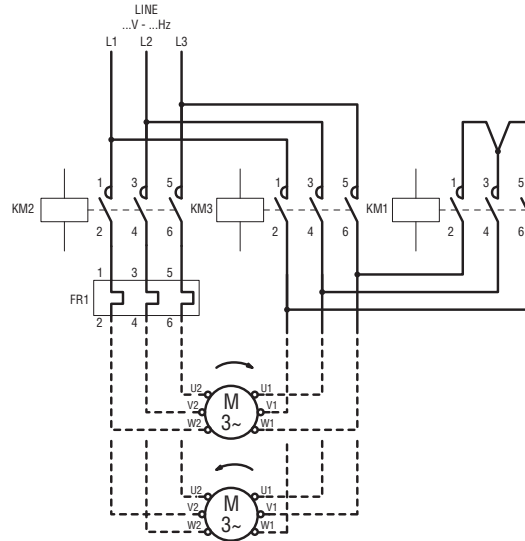

4

BFA009 70... BFA025 70
M3P009 70...M3P025 70

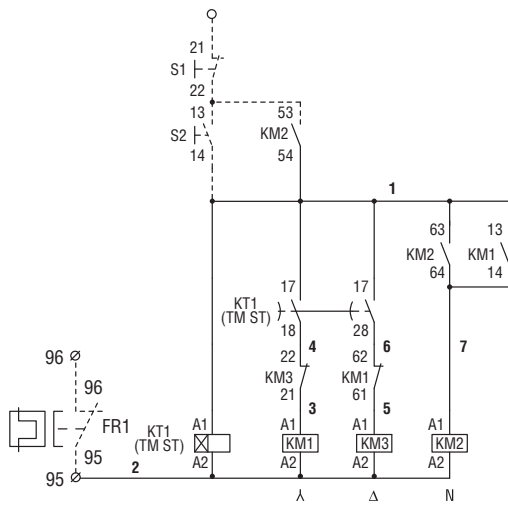

BFA26 70 - BFA038 70
M3P026 70...M3P038 70

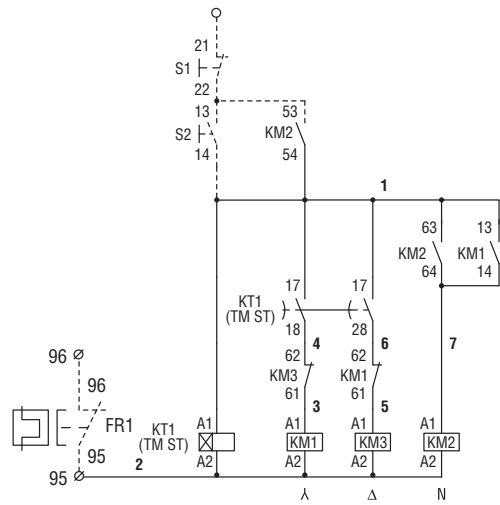

Electromechanical starters

Wiring diagrams

STAR-DELTA STARTERS, OPEN FRAME

DYF50... DYF95

4

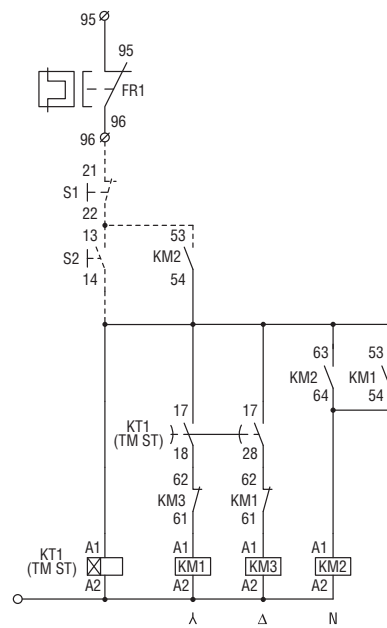
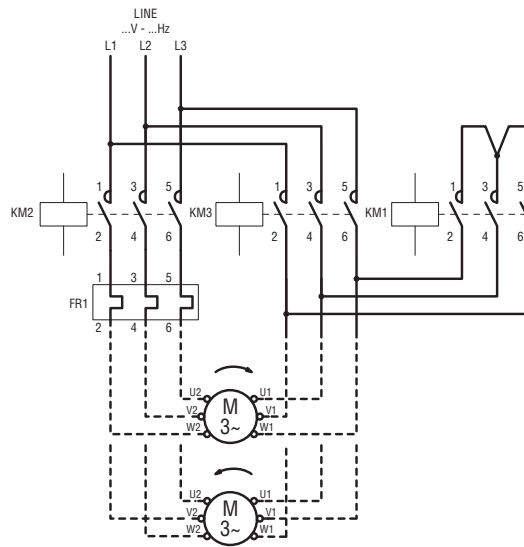

Electromechanical starters

Wiring diagrams

STAR-DELTA STARTERS, OPEN FRAME

NYF...

4

