

Datasheet - rope tensioner S 900

Further accessories for Pull-wire switches / rope tensioner



Preferred typ



- Smooth adjustment
- Only one tool
- Antiskid
- Time-saving
- Ergonomic
- No risk of injury

(Minor differences between the printed image and the original product may exist!)

Ordering details

Product type description	Seilspanner S 900
Article number	101186704
EAN code	4030661347295
eCl@ss	27-37-12-81

Global Properties

Product name	Seilspanner
Material	Plastic
Weight	250 g

Documents

Operating instructions and Declaration of conformity (en) 214 kB, 25.06.2015

Code: mrl_s900_en

Operating instructions and Declaration of conformity (de) 224 kB, 23.06.2015

Code: mrl_s900_de

Operating instructions and Declaration of conformity (pt) 214 kB, 29.06.2015

Code: mrl_s900_pt

Operating instructions and Declaration of conformity (cn) 306 kB, 17.07.2015

Code: mrl_s900_cn

Images

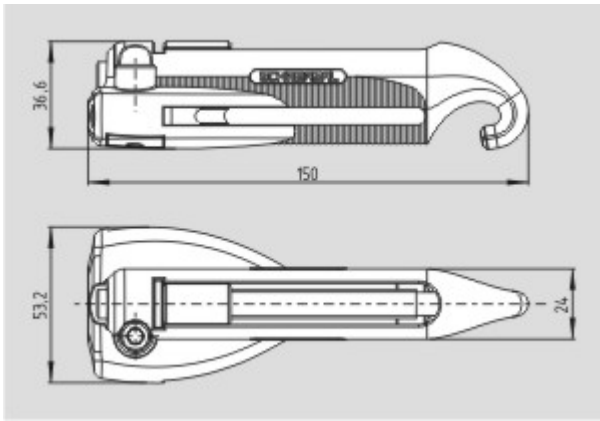

Dimensional drawing (basic component)

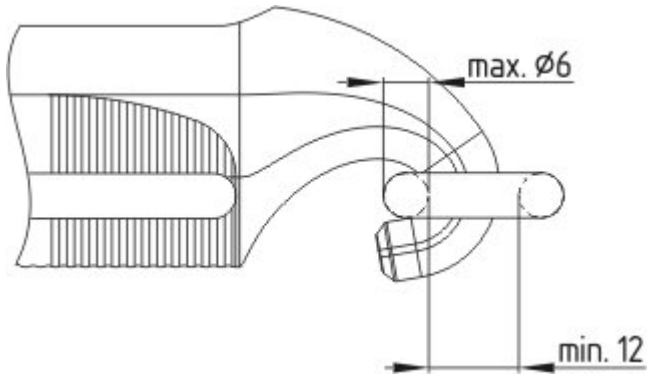

Dimensional drawing (miscellaneous)



Product in the environment

K.A. Schmersal GmbH & Co. KG, Mödinghofe 30, D-42279 Wuppertal

The data and values have been checked thoroughly. Technical modifications and errors excepted.

Generiert am 26.01.2016 - 02:48:57h Kasbase 3.2.1.F.64I