

Datasheet - EX-BNS 250-11Z-3G/D

Safety sensors / EX-BNS 250



- Ex certified
- Thermoplastic enclosure
- Small body
- 33 mm x 25 mm x 13 mm
- Concealed mounting possible
- Long life
- no mechanical wear
- Insensitive to transverse misalignment
- Insensitive to soiling

(Minor differences between the printed image and the original product may exist!)

Ordering details

Product type description	EX-BNS 250-11Z-3G/D
Article number	101179979
EAN code	4030661332598
eCl@ss	27-27-24-02

Approval

Approval	ATEX
----------	------

Classification

Standards	EN ISO 13849-1
B10d Opener/Normally open contact (NC/NO)	25.000.000
- notice	at max. 20% contact load
Mission time	20 Years
notice	$MTTF_d = \frac{B_{10d}}{0,1 \times n_{op}}$ $n_{op} = \frac{d_{op} \times h_{op} \times 3600 \text{ s/h}}{t_{cycle}}$

Global Properties

Product name	EX-BNS 250
Standards	EN 60079-0, EN 60079-15, EN 60079-31, IEC 60947-5-3, EN 13463-1,

Compliance with the Directives (Y/N) 

Yes

Materials

- Material of the housings	Plastic, glass-fibre reinforced thermoplastic
- Material of the cable mantle	PVC
Housing construction form	Block
Weight	43 g
Coding available (Y/N)	Yes
Monitoring function of downstream devices (Y/N)	No
Prerequisite evaluation unit	Yes
Recommended safety-monitoring module	
Recommended actuator	EX-BPS 250-3G/D

Mechanical data

Design of electrical connection	Cable
Cable length	1 m
Conductors	4 x 0,25 mm ²
AWG-Number	23
mechanical installation conditions	not flush
Active area	front side
Ensured switch distance ON S _{ao}	4 mm
Ensured switch distance OFF S _{ar}	14 mm
Type of actuation	Magnet
Direction of motion	head-on with regard to the active surface
resistance to shock	30 g / 11 ms
Resistance to vibration	10 ... 55 Hz, Amplitude 1 mm
Impact energy	max. 1 Nm

Ambient conditions

Ambient temperature	
- Min. environmental temperature	-25 °C
- Min. environmental temperature	-25 °C
- Max. environmental temperature	+70 °C
Storage and transport temperature	
- Min. Storage and transport temperature	-25 °C
- Min. Storage and transport temperature	-25 °C
- Max. Storage and transport temperature	+70 °C
- Max. Storage and transport temperature	+70 °C
Protection class	IP67

Electrical data

Integrated Safety monitoring module available (Y/N)	No
Cross circuit/short circuit recognition possible (Y/N)	Yes
Voltage type	VDC
Switch frequency	max. 5 Hz
Switching voltage	24 VDC max.
Switching current	100 mA max.
Switching capacity	1 W max.

Outputs

--	--

Design of control output	Other, Reed kontakts
Number of shutters	1 piece
Number of openers	1 piece

Electrical data - Safety outputs

Number of secure semi-conductor outputs	0 piece
Number of secure outputs with contact	0 piece

Electrical data - Diagnostic output

Number of semi-conductor outputs with signaling function	0 piece
Number of outputs with signaling function that already have a contact	0 piece

LED switching conditions display

LED switching conditions display (Y/N)	No
--	----

ATEX

	EX II 3D Ex tc IIC T80°C Dc X EX II 3G Ex nC IIC T6 Gc X
Explosion protection categories for gases	3G
Explosion protection Zones for gases	2
Explosion protected category for dusts	3D
Explosion protection Zones for dusts	22

Dimensions

Dimensions of the sensor	
- Width of sensor	33 mm
- Height of sensor	25 mm
- Length of sensor	13 mm

notice

Contact symbols shown for the closed condition of the guard device.
The contact configuration for versions with or without LED is identical.

Included in delivery

Actuators must be ordered separately.

Keywords

Keywords	Ex, EEx, ATEX, Ex BNS250, Ex BNS 250, BNS250 Ex, BNS250ex, BNS 250ex, ATEX BNS 250
----------	--

Diagram



Note Diagram



positive break NC contact



active



no active



Normally-open contact



Normally-closed contact

Documents

Operating instructions and Declaration of conformity (da) 247 kB, 03.06.2013

Code: mrl_ex-bns250_da

Operating instructions and Declaration of conformity (de) 293 kB, 26.10.2012

Code: mrl_ex-bns250_de

Operating instructions and Declaration of conformity (it) 464 kB, 03.08.2011

Code: mrl_ex-bns250_it

Operating instructions and Declaration of conformity (fr) 464 kB, 12.07.2010

Code: mrl_ex-bns250_fr

Operating instructions and Declaration of conformity (pl) 286 kB, 23.09.2014

Code: mrl_ex-bns250_pl

Operating instructions and Declaration of conformity (jp) 654 kB, 14.09.2011

Code: mrl_ex-bns250_jp

Operating instructions and Declaration of conformity (nl) 291 kB, 08.11.2012

Code: mrl_ex-bns250_nl

Operating instructions and Declaration of conformity (pt) 252 kB, 03.06.2013

Code: mrl_ex-bns250_pt

Operating instructions and Declaration of conformity (es) 260 kB, 12.12.2012

Code: mrl_ex-bns250_es

Operating instructions and Declaration of conformity (en) 292 kB, 26.10.2012

Code: mrl_ex-bns250_en

Operating instructions and Declaration of conformity (cs) 263 kB, 03.06.2013

Code: mrl_ex-bns250_cs

Brochure (de) 7 MB, 25.02.2011

Code: b_atep01

Brochure (en) 8 MB, 28.08.2012

Code: b_atep02

Brochure (it) 3 MB, 20.07.2007

Code: b_atep05

Brochure (es) 5 MB, 18.08.2009

Code: b_atep09

Images

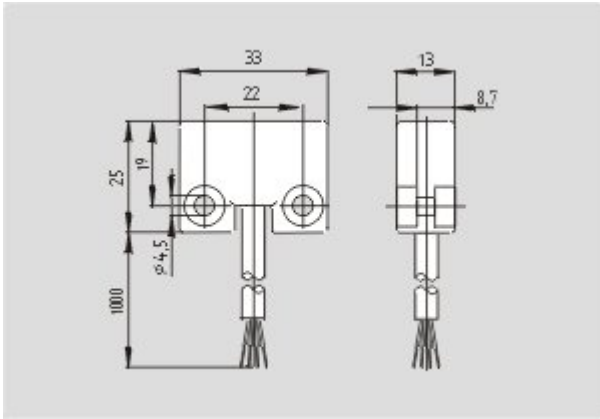

Dimensional drawing (basic component)

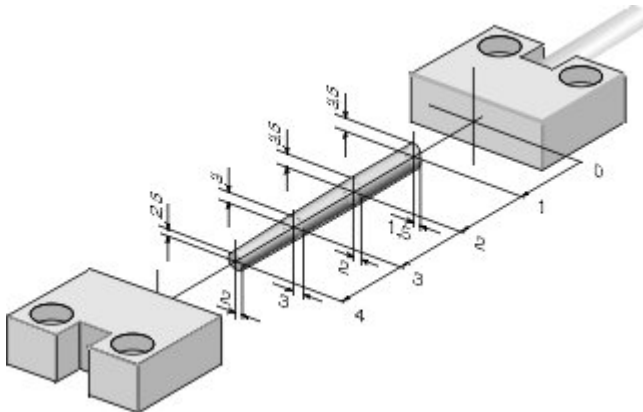

Characteristic curve

System components

Actuator



101183235 - EX-BPS 250-3G/D

Accessories



101131223 - SPACER BNS 250

- to mount the magnetic safety sensor and actuator on ferromagnetic material
- Suitable for food processing industry